

THE SETOFF

THE OFFICIAL PUBLICATION OF NARCOA
NORTH AMERICAN RAILCAR OPERATORS ASSOCIATION

MAY / JUNE 2008
VOLUME 22 - No. 3

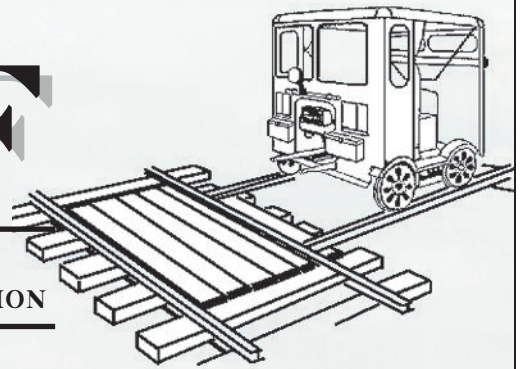

**RAILCAR WIDOW
NEW RULES
A CAR TURNTABLES
EC TEST RESULTS**



THE SETOFF

VOLUME 22 - No. 3

The SETOFF is the official publication of the North American Railcar Operators Association (NARCOA) and is published bi-monthly to promote safe legal operation of railroad motorcars, and to encourage fellowship and exchange of information among motorcar enthusiasts. Membership in NARCOA, which includes a subscription to The SETOFF is \$30 per year, and is available from Secretary Joel Williams. Please send your check made out to NARCOA to:

Joel Williams, Membership
Box 802
Lock Haven, PA 17745

Wayne Parsons, SETOFF Editor
13380 Golden Valley Lane
Granada Hills, CA 91344
setoff@ix.netcom.com

The SETOFF is printed by
Greg Kightlinger, GEK Printing

All subscriptions must go to the Secretary, and all materials for publication must go to the Editor.

Materials received by the 15th of even numbered months will appear on the 1st of the next odd numbered month subject to editing for space. Please include your e-mail address and phone number. Electronic submissions are preferred. Text files must be in MS Word format with .doc extensions. Photo files must be high resolution with .jpg extensions. Printed photos are welcome. Please include the original negative when possible. Negatives will be scanned and returned. All other materials are archived, not returned. We cannot reprint copyrighted material without written authorization or proper attribution. Letters to the Editor must be signed and include an e-mail address or phone number for authentication. All such letters will be printed as discussed in the NARCOA policy book.

For more information about NARCOA, the safe legal operation of motorcars, and NARCOA affiliates located in Canada, the United States, and Mexico, please see our official website at:

www.narcoa.org

© Copyright 2008 - NARCOA. All rights reserved. Reproduction, by any means, in whole or part, by any party, is strictly prohibited.

ON THE COVER: The Durango & Silverton "High Line" rock cut in 2000. Photo by Wayne Parsons. See also back cover "Spotlight on an Affiliate."

PRESIDENT'S MESSAGE

WARREN RICCITELLI

Welcome to the "new Setoff". You may see some things that are different and if not, get to the doctors immediately. This is the first issue with Wayne Parsons as editor and I wish to thank him for bringing fresh ideas and a new perspective to the Setoff.

Wayne is bringing to the Setoff his years of experience as a motorcar operator, an amateur photographer, and his knowledge of design and layout from his time at an advertising agency. In the coming months more features will be added. Don't be surprised if you submit a technical article and he schedules it way in the future. He is trying to plan ahead with scheduling that is taking us into next year. For example, the Spotlight On An Affiliate (upgraded to include color photos with placement on the back cover) is booked for the next five issues. Wayne asks that you send in run reports and photos right after you get home. That way run reports can appear in a more timely manner. I'm just staying out of his way.

In this issue, you will notice a NARCOA inspection check list and an article from Al Elliott on page 10. If you haven't been on a run this year, it is a good article to help you get your car ready. If you are already out running, check it over for you might have forgotten something that might end you up

on a towbar.

Today, I received word that the NARCOA FCC license issues are about to be resolved. This will clarify our use of radios in the Detroit area, upstate Maine and in Alaska.

And from Tom Norman comes news that we are above our estimates and ahead of last year's participation in the NARCOA insurance program. See his article on page 18 for a little history of the insurance program.

Also included in this mailing is our first NARCOA roster in four years. Because of the tremendous cost of the Roster, we are planning ahead with a yearly update to be mailed to all. The three hole punch allows for you to put the roster in a binder and add the yearly updates as they arrive. We are looking at a four year time frame before the next complete roster printing. Due to space, the listings are limited to two motorcars per member.

And with all the primaries over, the snow melting and knowing you will fill in your NARCOA ballot (also included in this mailing) before going to page three, let the motorcar year begin!

And let's all be safe out there...

Warren

IN THIS ISSUE

Masthead	2	Posting Excursions.....	13
President's Message.....	2	A-4-E Turntable Plans	13
NARCOA Officials	3	A-4-E Turntable Drawings	14
From The Editor.....	3	Turning Gang Cars.....	16
Directors' Messages.....	4	Insurance Program History	18
Railcar Widow	7	Farmrail in Oklahoma	18
Winter Run In Georgia.....	8	EC Test Results	19
"The Fugitive" Train Wreck	8	Excursion Announcements	20
Saint Marys Railroad	9	For Sale Items	27
Wheels	9	Spotlight On An Affiliate	
Inspection Form.....	10	(Patrick Smith)	Back Cover
New Rules	12		

ANTONITO

NARCOA OFFICIALS

President: Warren Riccitelli
Vice-President: Bobby Moreman
Secretary: Joel Williams
Treasurer: Tom Norman

Area 1 Director
(ME, NH, VT, NY, MA, CT, RI)
Warren Riccitelli (401) 231-5640
39 Jackson Drive
North Providence, RI 02911
warren.riccitelli@verizon.net

Area 2 Director
(NJ, PA, DE, MD)
Joel Williams (570) 786-1335
joel.williams@earthlink.net

Area 3 Director
(IN, Lower MI, OH)
Bruce Carpenter (419) 738-5384
bnsf89@bright.net

Area 4 Director
(WV, VA, KY, NC, SC, TN)
Tom Falicon (828) 488-8063
raildawg@gte.net

Area 5 Director
(MS, AL, GA, FL)
Bobby Moreman (770) 457-6212
moreman@mindspring.com

Area 6 Director
(MN, WI, IL, Upper MI)
Hank Brown (608) 839-4939
wildernesstours@charter.net

Area 7 Director
(ND, SD, NE, IA)
Carl Schneider (515) 967-5181
motorcarl@mchsi.com

Area 8 Director
(Canada, World outside U.S.)
Warren Froese (204) 668-8311
wsfroese@shaw.ca

Area 9 Director
(AR, CO, KS, LA, MO, OK, TX)
Mark Springer (316) 721-4804
lospinos@cox.net

Area 10 Director
(WA, OR, ID, MT, AK, WY)
Jim Spicer (541) 344-3079
jimarea10@aol.com

Area 11 Director
(CA, NV, UT, AZ, NM, HI)
Pat Coleman (925) 979-1030
patcoleman@astound.net

Director-at-Large (non-voting)
Bernie Leadon (615) 478-3660
leadon@reallysmall.com

Director-at-Large (non-voting)
Dave Verzi (216) 941-5273
WM340@aol.com

Nominations, Elections
Carl Anderson
1330 Rosedale Ln.
Hoffman Estates, IL 60195
ca636@aol.com

NARCOA Insurance Administrator
Tom Norman (406) 722-3012
1047 Terrace View Drive
Alberton, MT 59820
alb4961@blackfoot.net

Rule Book Certification Test
Al McCracken
2916 Taper Avenue
Santa Clara, CA 95051
ALNETHIE@aol.com

Judiciary Chair
Al Elliott (732) 536-7460
4 Woodview Drive
Manalapan, NJ 07726
hajelliott@optonline.net

Safety Chair
Bob Knight (815) 786-3096
railbuff@indianvalley.com

Rules Chair
Jim McKeel (316) 721-4378
cp2123@cox.net

The SETOFF Editor
Wayne Parsons (818) 368-5942
13380 Golden Valley lane
Granada Hills, CA 91344-1118
setoff@ix.netcom.com

NARCOA Webmaster
Keith Mackey (352) 347-0770
webmaster@narcoa.org

NARCOA Forum Moderator
Rich Stivers (408) 264-1048
rich@stivers-bros.com

Committee Chairs
Operations Hank Brown
Rules Jim McKeel
Judiciary Al Elliott
Safety Bob Knight
Affiliates Dave Verzi
Custom-Built Motorcars Tom Falicon
Communications Bernie Leadon
Data and Computer Pat Coleman
FRA Ron Zammit
Legal Forms Mark Springer



NARCOA Licensed Radio Call Sign
WPHT745 - 151.625 MHz

FROM THE EDITOR

NARCOA has invested in Quark, a professional layout program, used to create this edition of The SETOFF. Your new editor's goal is to use modern typefaces, a modest artistic bent, and the power of Quark to get the most out of every page printed and mailed to you, the membership. Several layout choices have been made to accomplish this mission.

The first choice is typefaces. All typefaces used in articles and headlines of The SETOFF going forward are categorized as "Roman" serif. Serif typefaces are named for the features at the end of their strokes. The body of articles uses Times New Roman. Two font packages, **NORTHERN PACIFIC RR ROMAN** and **CLINCH (CLINCHFIELD RAILROAD) ROMAN**, purchased from www.RailFonts.com, are being used for headlines and by-lines. A fourth font called **RR SIGN** will create accents.

The second layout choice is a change to three columns across the page. This approach matches newspapers, and my favorite publication, "Trains" magazine. Using right and left type justification within the columns allows more words per page. Quark easily inserts type and picture boxes into pages with control of "runaround" at the edge of those boxes.

Third, thanks to the generosity of our printer and publisher Greg Kightlinger, color photos are on both the front and back covers.

The SETOFF is limited to 28 pages (including announcements) for budget reasons. With the changes in layout, the same amount of material as before, and possibly more, can print in this fixed page count.

Finally, vertical (portrait) format photographs get first consideration for publication. When you see a nice shot, please take the time to turn your camera upright and include a little bit of sky!
Wayne Parsons - *Editor*

What are the names in the little boxes? They're stations or control points as listed on a timetable or train schedule for a railroad in North America. Which railroad is disclosed somewhere in the excursion announcements.



AREA FOUR

KY, NC, SC, TN, VA, WV

TOM FALICON

Hi Area four Members,

It's with deep sorrow that I once again tell you that we have lost another member of our Area Four motorcar family. Bill Coker of Athens, TN left us March 10th. Bill was a master millwright, he reminded me of the kind of guys you see on that TV show called Mega Movers. He had the men, machines and skill to move damn near any piece of equipment with ease, taking crap from no one in the process! He was a relatively new member to our motorcar family but he took to our hobby like a fat lady to a cheesecake and fortunately, he managed to cram a lot of running into his 2007/8 season. I was lucky enough to ride with him on some rare mileage runs and I am so happy that we got to enjoy each other's company at those events. Bill had a knack for coming up with sayings and phrases that were so colorfully funny I couldn't wait to hear what he was going to say next..... John, the torch has been passed; I think we're all going to be expecting to hear you start uttering some of your dad's funny expressions pretty soon! Bill Coker was one of the Area Four/Five members that caught the "Beaver Car Fever" that was running rampant through the mountains last year. Bill and I seemed to be bonded a little bit closer by the fact that regardless of all their quirks and noises, the eight man diesel Beaver Car was our favorite and neither of us would trade ours for the world. From now on whenever I crank up my Ol' Lister diesel and hear it roar to life, I'm going to think of you, Bill, and take you along for the ride.

Just when you thought it couldn't get much more expensive to attend a motorcar excursion we get spanked with even higher fuel, food and travel costs. When I wrote about this fact a while back, I assumed that things would somewhat level off. Well, my assumption sucked and now here we are wondering if we need to apply for small loan just to fill up our fuel tanks??? As excursion attendees we may need to resort to some of the things I suggested in the past such as carpooling or possibly sharing a motorcar or motel room at an event there-by splitting the

cost in half. Attending events that are close to home could be beneficial by having no motel costs and lower fuel costs. Our hobby is too strong to let some financial woes keep us down. I've talked in the past about what a resourceful lot you guys are and I think it's time for you all to be even more ingenious than ever! I feel that this challenge of the higher cost of everything will bring out the inventor in all of us and I hope to soon start hearing about some money saving ideas and inventions you guys have created.

In the retiring Area Directors dept: I disagree with Area 3's Director, Bruce Carpenter referring to other Board Members as "old timers" and also disagree with Bruce and retired Area 8 Director Ken Annett both suggesting that current directors step aside to allow new blood to take over. Each current director does his job to the best of his ability and I cannot think of one man that does not give an extra effort to everything they do pertaining to NARCOA. We'd like to remind you that every NARCOA member has the ultimate choice as to who their Area Director will be. Any NARCOA member can nominate a fellow member that they think will do the job for their area. Unfortunately, it doesn't seem like there is an overabundance of candidates willing to devote the large amount of time, responsibility and dedication it takes to perform this thankless job. I've always told you guys in Area Four that if they ever feel that I am not giving you 110% let me know and we'll get someone into office that will do a better job than me. I've been told that my reward for being an Area Director is being able to attend the Annual Board meeting and have my motel room paid for. Well, I can't think of anyone who would consider spending three days in a Chicago hotel that was built at the end of the O'Hare Airport's runways a reward. My reward as an Area Director is being able to assure smiling faces and good, safe, family fun at motorcar events across this country and if that's what it means to be an "old timer" then call me one!

In the corrections/additions dept: In my last director's letter where I paid tribute to lost Area Four family member Evan Roderick. A sentence that told the fact that it was my first motorcar excursion ever was somehow left out and the next sentence was modified to make no sense. Sorry for the confusion!

I'd like to welcome Wayne Parsons aboard as our new Set-off Editor. He's already doing a great job as you can see from the new look of this issue. We'd all like to thank him for his efforts!

I'd also like to take a minute to praise our webmaster Keith Mackey. Keith is the guy that has our web site looking so very professional and keeps it so very current. He also is the guy that posts your want ads and excursion announcements almost immediately with no problems what-so-ever. Thanks Keith.... You da man!

Thanks for talking with me guys, stay strong, Tom Falicon, NARCOA Area Four Director

AREA FIVE

MS, AL, GA, FL

BOBBY MOREMAN

For those of you that have been in NARCOA for several years, you will recall the tremendous number of changes that NARCOA has had. Most will think of rule and procedure changes, and that is important in the ever expanding world of business. We, as a NARCOA business, yet also a hobby, must accept that changes are important for the good of NARCOA, and for NARCOA to survive successfully.

You senior members will also remember the succession of officers, area representatives, chairpersons, committee members that make up the backbone of the administration of your NARCOA organization. Every year is election year, somewhere in NARCOA. This year is again your opportunity, as members of NARCOA, to make your selection of who is to best serve you in your area. It is your duty, and responsibility to look carefully at your area representative, and vote or nominate a responsible person to govern your area and NARCOA.

A major change this year in NARCOA is the retirement of 'Charlie' Morvey, your past SETOFF editor, and the appointment, and acceptance of Wayne Parsons as your new SETOFF editor. We will miss 'Charlie' and her tremendous input to NARCOA as our editor. Wayne Parsons comes with the best of recommendations and he is working very hard

BIG HORN

to continue the success of the 'SETOFF'. We wish Wayne our best, and offer him our help and advice. Seems like we just get better and better, and we learn from each succession of officers, area representatives, chairpersons, and committee members.

I hope that you will always remember that NARCOA is your organization, and like all volunteer organizations, we need your thoughts, comments, and suggestions to successfully keep NARCOA a respected part of the railroad community.

Just as we all keep a set of tools in our motorcar to make the inevitable repairs, your elected representatives are there to make the needed repairs for your NARCOA organization.

I'll close with another thought on tools. Do you know what a RTAFA is? It is simply a 'rotational torque-adjustable fastener applicator'. Growing up in south Georgia, we called it a 'screwdriver.'

Brenda and I wish all of you a safe motorcar year.
Bobby Moreman - Vice President

AREA SIX MN, WI, IL, UPPER MI HANK BROWN

March 8, 2008 was a great day to be in Region 6. The annual meeting for North Central Railcars was held at the Pizza Hut in Madison, Wisconsin. There were 20 members present. Safety issues by Bob Knight, NARCOA's own Safety chairperson, and on Operations by me, were presented.

Two very important items that Bob mentioned were the use of safety vests and following the rules. President Ott brought up the issue of members follow-

ing to close to the car ahead. Most of the incidents we review on the Judicial Committee relate to following distance. The rule book states that an operator should allow 10 to 12 seconds spacing. However, this does not take into consideration the speed at which the motorcar must operate to arrive safely at a destination at a reasonable time. Higher speeds require greater spacing between cars.

I brought up the issue of seat belts. NARCOA does not require them and probably will not until someone comes up with a fool proof way to install them. However, it will become mandatory to use them on Canadian railroads. I strongly support the use of them. I have been on the Judicial Committee and every year we have to review someone running into the back of another car. People have been injured because they, either didn't have seat belts, or didn't use them.

The excursion schedule for Region 6 is not what we would like, but there will be excursions around the region. We have been working with the Wisconsin & Southern, the CPR and CN. East Troy Trolley Museum continues to support NARCOA.

We will continue to offer new operators a mentoring program. If you are a new member in Region 6 and want to be mentored, contact Dave Otet (920-668-8677), Hank Brown (608-839-4939), or Dave Hawley (630-854-8052). Remember that the only way we can continue to ride the rails is by doing it safely. So stay focused.

Hank

WATCH YOUR STEP



Region 6 - North Central Railcars annual meeting attendees.

Photo by Dave Hawley

AREA SEVEN ND, SD, NE, IA CARL SCHNEIDER

By the time this newsletter hits the mail, many of us will have already have begun our ride season. Having said that, I hope everyone had the opportunity to go completely through their cars ahead of time to see that they are ready for safe trouble-free operation. It's the responsibility of the operators to make sure their car(s) meet the safety criteria of NARCOA, even though local safety officers will be checking cars to see that there are no defects that could possibly cause problems on the rails. We want 2008 to be the safest ride season ever!

I have been doing a newsletter for the First Iowa Division (FID) for many years and have been doing both snail mail and e-mail versions. With postage going up again and with many more of our members joining the ranks of computer users, I will no longer be snail mailing the newsletter. Instead, I'll be doing an article in The Setoff to keep our snail mail members up to date on what's happening in the area.

Area 7 has been blessed with some new rail to ride. One of the neatest additions to the FID schedule is the Iowa River Railroad which we ride both directions out of Eldora, Iowa. This is an ex-M&StL, CNW, and lastly UP branch line that was purchased by shippers to service grain elevators and an ethanol plant.

We rode the line twice last year and have scheduled it for two excursions again this year. The tracks, which follow the Iowa River, are very scenic, and they are in surprisingly good condition for motor car operation. Come join us, as this has become a very popular ride in a very short time. Even though the tracks are in Iowa, it's not just corn and bean fields for scenery!

Let's all get out there now and have a fun summer riding the rails!



SUBLETTE

AREA EIGHT CANADA, MEXICO, AUSTRALIA WARREN FROESE

Greetings from the Great White North on behalf of Canadian, and international members. The snow is actually beginning to melt on the prairies and soon we will be able to find our motorcars!

This last fall was my first experience at our annual BOD meeting in Chicago, and it was a refreshing event with a group of very committed people, many for the long haul. Please remember that your thoughts and comments are always welcome and you are encouraged to call or email any time (wsfroese@shaw.ca or 204 668 8311). I would encourage each of you to consider attending the meeting at some point and make some time to enjoy Chicago and the meeting.

This summer runs are planned in southern Saskatchewan (Great Western Railway – June 23 – 27) and northern Ontario (Algoma Central Railway – July 28 – 31). These are both beautiful runs through very interesting and diverse territory. A reminder to our American members, these excursions provide great running, and are close to your northern border. There are also many excursions in neighboring northern states – east, mid-west, and west, as well as Alaska. Take some time now to browse the excursion list and make your choices.
Warren Froese – Area 8

AREA NINE AR, CO, KA, LA, MO, OK, TX MARK SPRINGER

Another spring is upon us, and of course, that means it is time for another season of operating our motorcars. It is gratifying to continue to see new members join the hobby and to have new people volunteer to participate in the hobby. I have seen rides for Texas, Colorado, and Oklahoma already scheduled. I also have heard of some rides in Kansas that should be announced soon.

This year is going to bring our hobby some new challenges with the ever increasing cost of fuel. I certainly hope that

each of you will continue to be able to attend rides. I also hope that each affiliate will do what they can to make the rides as affordable as they can arrange.

Currently the Board of Director's has been having some discussions about the criteria used to certify new Excursion Coordinators. With several relatively new groups in our area this is an especially important issue. Personally, having operating experience with several different Affiliates and Excursion Coordinators is a plus. Having several years of experience in the hobby is also a plus. Volunteering to help on excursions is also helpful. Most importantly we need people who are organized, responsible, and interested in running a safe ride. If you have input on other criteria you would like to see included or excluded, please contact me.

Lastly, for many of us, we have not operated our motorcars since last fall. The first rides of the season are when we need to be especially careful. It is easy to get rusty and need a little bit of time to remember exactly how your car stops, accelerates, and handles rough track. The most important safety item is a cautious, aware operator. Be safe.

AREA TEN WA, OR, ID, MT, AK, WY JIM SPICER

Greetings from the Far Corner.

For Charlene's last edition as editor I sent my contribution to the Setoff. I thanked her for her years of dedication and service as editor. Unfortunately, between its arrival and the final layout, my message was misplaced, and was not printed. I also encourage all of you to contribute stories and information to our new editor Wayne Parsons.

I have seen some of Wayne's preparations for this edition and am excited about what he is doing. Let's all support Wayne in his efforts as editor.

We have a lot of dedicated volunteers besides the directors. There are committee chairmen, committee members and on all the trips, EC's and their helpers. The two that do the most for our organization are our insurance representative and the Setoff editor. Next time you see any of these volunteers, go out of

your way to thank them for their efforts.

Good news; under the new EC certification program, Area 10 now has twelve certified coordinators. Bad news; I hear complaints from all EC's about participants arriving at events without doing the advance paperwork. If you get in line at the set-on point without your paperwork being completed, be prepared to go back to the end of the line until it is finished. You have been warned.

We have a lot of great events in the NW this year. The list is constantly changing and being updated. To get the latest information, go on line and check the schedule. One thing you will not find on the calendar this year is that they would again like speeder representation at the Issaquah Train Depot Saturday, July 26. You can contact Tom Gilcrist 206-719-5931 direct.

Since you have all worked hard on your motorcars this winter and they are in tip top shape, we will have no break downs or accidents.

See you on the rails, Jim

AREA ELEVEN CA, NV, UT, AZ, NM, HI PAT COLEMAN

A number of runs are being offered in Area 11. All are our old favorites at Sierra, McCloud, Skunk, CA Northern, and perhaps Niles. For those that think they have seen it all because you ran once on a line, you are missing the camaraderie and joy of your fellow operators.

Unfortunately, we have been turned down by CORP and AZ & CA. Those turndowns have resulted from decisions by corporate owners of CORP and AZ & CA. So, talking to the local folks will not advance our cause. Our NARCOA President and I plan to visit corporate after the September 2008 Annual meeting to discuss how we can resolve the situation to the satisfaction of both parties.

At McCloud, we believe the UP cars in storage near Upper Yard will be removed by the time of late the May run. We'll be able to run from McCloud to Burney on Saturday. The McCloud runs will be at speeds to permit enjoyment of scenery and safety of operation. The McCloud tracks not currently in operation, will be closely reviewed prior to the SWRC runs.

Sierra RR management reports the

Skunk line tracks between Willits and North Spur clear of wash outs and fallen trees. Contrary to rumors, my sources say that the Sierra RR is not for sale.

PRO is sponsoring a CA Northern run in late April. This is a great run as the track has great visibility, and is in very good shape from its days as high speed SP track.

For you 2-stroke fans, MOW is sponsoring a belt car only run on the Skunk from Willits to Northspur, and return.

Niles is being reviewed for future runs with a different twist to avoid the noise issue in Sunol. I will have more on this RR in next issue.

Finally, please check out your cars before the season starts using the information in the inspection form article on page 10. Sadly, I've seen operators drive thousands of miles to an event and not have enough gas in their speeder to get out of the yard.

Best regards,
C. Patrick (Pat) Coleman
Walnut Creek, CA

NOMINATIONS, ELECTIONS CARL ANDERSON

It is that time of the year when half of NARCOA votes to elect board members to two year terms. This year all ODD areas are voting, and there were no new nominations from the membership. Thus all incumbent Board members are running unopposed. Nevertheless, your vote is very important. The Board members look to see what percentage of people in their area voted. They each see this as an affirmation of the work they are doing in support of NARCOA. Please take the time, when you get your hard copy of the Setoff, to vote. Don't let your vote fall through the cracks.

DIRECTOR AT LARGE BERNIE LEADON

Keith MacKey reports that Ferromex did not approve a motorcar event in Mexico's Copper Canyon this year "due to new security rules." This may be due to a general deterioration in security in northern Mexico. Ferromex said they would be happy to have us inquire again in the future.

RAILCAR WIDOW

BY MRS. DIANA NORTH

Lewes, Delaware - Now, don't be alarmed! My husband Mark is alive and well. I know this because he answers his cell phone! It all started a year ago. A friend of mine invited Mark and my son, Jack, to the Amtrak Open House in Bear, Delaware. Yes, a "railcar" was on display!

After that day, part of my family began disappearing before my eyes! So, you say there is an association of people collecting old railcars, restoring them and going for a ride - ALL YEAR LONG!! Whoa!! A short time later, I got that phone call from my husband saying: "Now don't laugh". Okay, he is backing his trailer up our driveway with "something" on it!? I know it is definitely made

with a REALLY NICE SHOP!! Between new and old friends, parts and exact paint colors, a motorcar is given new life to ride the rails again.



This past November, I experienced my first excursion with this curious group of people. Mark, Jack, Megan, and I, along with the group, started in Georgetown, Delaware and rode to the Cape May-Lewis Ferry on the Delaware Coast Line Railroad. Back and forth, up and down...stop and start with red flags in and out. We bumped along familiar territory that I had never really "seen" before. For as many times I have taken my children to Lewes Beach, I've never trekked along a railroad to see Lewes from the "backside".

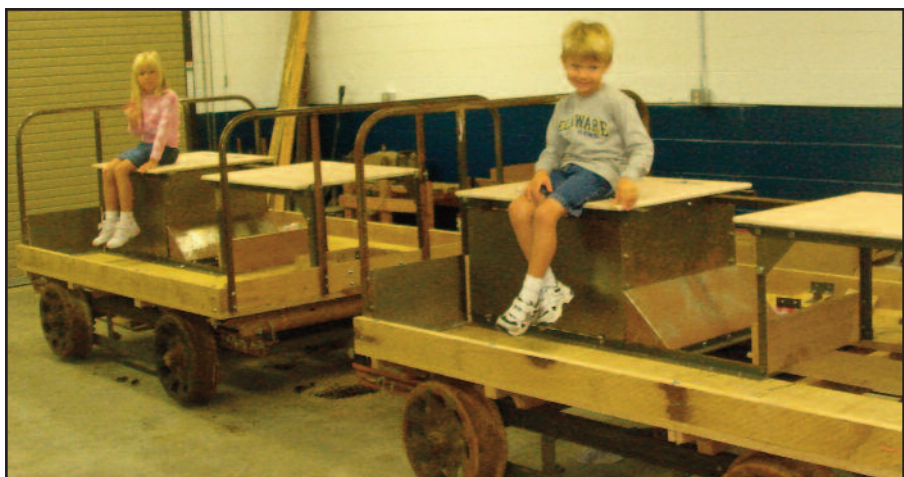

Future motorcar operators Megan and Jack North sit on Dad's A cars (built in 1947) that came from the Chessie System. Photos by Diana North

of metal...but what the heck is it? "And you say there are two 'somethings' on the trailer?" Mark is laughing, and I am rifling through our medical records to make sure we are up-to-date with tetanus shots!

From that day forward, my family now spends endless hours at the shop restoring railcars. Mark has a new friend with many connections, and an old friend

We walked into town for lunch, and even watched a man open a swing bridge with a really big "key!" Afterwards, we returned to the railcars for the trip back to the trailers, watching the swirling leaves behind us.

Weekend excursions, "kitchen passes" and endless phone calls with railcar friends - I have become a "Railcar Widow", and it's okay.

WINTER RUN IN GEORGIA

THE BALL GROUND ADVENTURE

BY ANNE HERRON HYMEN



On a cold, snowy January 19, 2008, thirty very hardy people bundled up from head to toe and started on the 48 mile journey from Blue Ridge, GA (near the Tennessee – North Carolina – Georgia border) south to Two Brothers BBQ in Ball Ground, GA (near Canton).

We had decided to stop in two hours to try to straighten our frozen bones and joints. Our porta-potty, towed behind the lead car, was quickly attacked when we made our first stop. We walked around stretching our legs, and enjoyed the snow flurries. As we continued south the snow came down harder. The question “Are we going to get home?” was being asked by many.



Photos by Anne Herron Hyman

The BBQ at Two Brothers was good as usual and just as we finally thawed out, (Oh No!) it was time to leave. We all bundled back up in our coats, hats, and gloves. Some riders even had foot warmers taped to the outside of the boots to help keep their toes warm. Back out into the blizzard we went and waddled back to our cars. Thank goodness we had turned the cars before we ate. After piling back into our cars we quickly started our 48 mile journey home.

As we approached Georgia Marble

near the town of Whitestone, the lead car stopped for a rest break. After 1 ½ hours of riding in the cold weather, everyone had a great need for the porta potty. Susan Long, a Blue Ridge Scenic Railroad volunteer known as the "HO Gauge Conductor," because of her diminutive size, bailed out of her car and headed for the porta potty. However, Susan had on so many clothes that while she was shedding layers, two guys had time to jump the line in front of her!

Our trip back to Blue Ridge was helped by two members driving ahead by road, and flagging all the crossings for us, saving lots of time. When we arrived back into Blue Ridge and our smiles had finally thawed, all of us talked about our snow ride, how much fun we had along the way, and how beautiful the ride had been. Despite the weatherman's prediction of two inches of snow, we did get one inch. What A Day!



A tip for a winter trip – offer the girls a second cup of coffee and they will warm the seat first! There are many types of coffee: there is fancy coffee like Starbucks, cheaper coffee like McDonalds and then you have decaf and regular. However, when will somebody invent a slow moving coffee? Then we could go further between stops! Come and join us next time on the Blue Ridge rails!

VISITING

“THE FUGITIVE”

TRAIN WRECK

BY JAMIE HAISLIP

Bryson City, NC was the set-on point for the 2007 year-end Great Smoky Mountain Railroad event near the National Park that straddles the eastern Tennessee and western North Carolina borders. One thing that drew me to this line was “A” cars are recommended and encouraged to participate. Meet Coordinator Tom Falicon allows belt cars, but mandates that they be towed over the mountain peak so their belts aren’t damaged on the climb to Andrews. I brought my newly restored A-4-E hoping to tow a couple of cars over the mountain.



Photos by Jamie Haislip

The first day of the run, December 31st, took us 16.5 miles east toward Dillsboro. The run, following the Tuckasegee River, was a very scenic ride through the country side. During the safety meeting we were told that the famous train wreck scene from "The Fugitive" was filmed here and we were going to stop at the site and have a quick look at it. I was enjoying the ride, which has many nice bridges and tunnels, when I recognized the tunnel that Harrison Ford had walked through during his getaway scene. I knew we were close and sure enough the crash site was just around the bend. Low and behold the train engines and the buses were still sitting there.

We pulled up and got a wonderful story from one of the local film makers who worked on the movie. The film makers spent 1.5 million dollars preparing the scene with 17 cameras set up to catch this one time shot. They had two locomotives and six buses. They shot the bus rolling down the hill first. The rail shot used two old locomotives that were pretty much stripped on the inside and dry so they wouldn't make a mess so

close to the water. A real locomotive was brought in to push the train toward the scene and at the right moment they cut away at 30 MPH and let err rip.

Out of camera range, the railroad installed a siding switch and a stub track to guarantee the train would “derail” when it hit the bus and slide off the track at the end. Additional pyrotechnics and a pit were there to add to the excitement. The camera crew had a pool bet on how far the locomotive would drag the bus down the tracks. Since it had never been done, it was a wild guess on everyone's part. The local film maker (our story teller) claims that he won the bet.

Back on the move again we run the rest of the short way down to Dillsboro. The GSMR excursion train soon arrives. It is really nice to hear the older EMD GP-9 diesels purr away there. Once back in Bryson City, Tom Falicon the EC provided a wonderful New Years Eve dinner at "The Station Restaurant". We pulled right up to the building, parked for the night, and went in to dinner.



The next day, January 1st, we head west and up the mountain to do the climb. The rail today gains one thousand feet in a twenty mile stretch. In one particular three mile section the grade increases to 5 percent! This is where the belt cars must be towed up the mountain, and released at the top. We follow the Nantahala River up to Lake Fontana where the line crosses over a nice, big, and high old truss bridge. The lake had been drained down approximately 25 feet to allow maintenance on the dam leaving house boats far from shore. There were tunnels, and several smaller bridges to add to the scenery.

This section of the line is very beautiful and I can't wait to go back and do it again. The mountain scenery, even in winter, looked great and I highly recommend it to anyone. Thanks go to Tom Falicon, and all the people at the Great Smoky Mountain Railroad, for hosting this run.

TOLTEC

SAINT MARYS RAILROAD

BY LARRY CROWE



Jay Boggs's A6 and Larry Crowe's A4 crossing trestle on St. Marys Railroad.

Photo By Larry Crowe

St. Marys, GA - Saturday, December 8, 2007 dawned with heavy fog in this town on the Atlantic Coast near the Georgia / Florida border. The excursion set-on point was at the Saint Marys engine house where a long strip of ground level track makes it easy to do a casual set on without traffic problems. Today's event is on the 11 mile short line that runs from the local paper mill on North River in Saint Marys to the CSX interchange at Kingsland, GA. The line has one 4 mile spur to the Kings Bay Navy Base.

A couple of prospective members arrived in time for the safety meeting, and were thrilled at getting the chance to go along with us for the day. One had found us through the NARCOA website excursion listings, and decided to drive over and see what it was all about. During the day several members took the time to talk with them, and show them the different makes and models of motorcars.

After the introduction of the railroad personnel, and discussions during the safety meeting, several caps with the Saint Mary's railroad logo were given out, along with fudge for each car! By this time the heavy fog began clearing enough for us to begin our trip.

Arriving at the spur track going to Kings Bay submarine base, we paused for a short break while a piece of track repair equipment was switched to a side-track. With the track clear, we proceeded to Kings Bay. There we turned the cars

and headed back to the main line and on to Kingston.

After passing through Kingston, we again turned and returned to restaurant row, where we parked and scattered to various restaurants for lunch. Following a long lunch break, we proceeded back to St. Marys at a slow enjoyable pace arriving back at the set-on point slightly ahead of schedule.

As usual, it was good to visit with many old friends and meet some new ones. A good day was enjoyed by all, without any incidents. Many thanks go to the St. Marys Railroad for allowing us to operate, and to their personnel for flagging the crossings. Thanks also to Excursion Coordinators Jim Garner and Jay Boggs of Southeast Railcar Operators for setting up the ride.

WHEELS

In January 2008 Harsco Track Technologies quoted the following prices for Fairmont wheels:

- 20" Cast wheels - \$1751.00 ea.
- 20" Pressed wheels - \$630.00 ea.
- 16" Cast wheels - \$1645.00 ea.
- 16" Pressed wheels - \$176.00 ea.
- 14" Pressed wheels - \$253.00 ea.

All prices FOB Cayce-West Columbia, South Carolina, USA. See web site www.harscotrack.com for contact info.

OSIER

BEFORE DEPARTURE: USE THE INSPECTION FORM TO GET YOUR CAR READY BY AL ELLIOTT

The NARCOA motorcar inspection form is on the web site under documents and forms. Lets take a closer look, and see what we can do to make everyone's excursion(s) more enjoyable.

The first two lines are directly related to the excursion, you, and the car you plan to operate. Fill these out along with your current rule book number, and

insurance number. Check off the items in the pre-inspection column as you work down the form. Remember this is a guide, and does not limit you from going further, and doing a check involving more than listed.

ON BOARD

Charged Fire Extinguisher "ABC" two pounds: available at "Home Depot"

"Lowe's" or "Target" under \$20. Mount it in an accessible area, as you may need it, and fast! Be sure the unit already carried in your car, indicates fully charged. Read the instructions that accompany the unit for life expectancy. It's a good idea to shake the extinguisher regularly to make sure the powder inside is loose, and not clumped together at the bottom.

First Aid Kit: available at "CVS", "Rite Aid", or "Drug Fair" type stores for around \$15. It may be you who needs these items; make sure all the pieces are inside. If some of the supplies have been used the kit is rendered semi-useless.

Two Orange or Red Flags: sounds obvious, but not every participant last year here in the east met this requirement. The Vinyl ones, stapled to a dowel, work fine, and can be had for \$3. We do some neat nighttime riding, and I recommend flags with a reflective strip on both sides to help nighttime visibility. You might consider adding a red safety wand to your flashlight. The new L.E.D. Light wands are available on the internet for around \$17.

Current NARCOA Rule Book: get the latest version from the web site. Keep a copy of it in a zip lock bag in your motorcar along with copies of your rule book certificate, and current insurance card. You are required to have a copy of all three



Version 2.1 09/29/06

Motorcar Inspection Form

Excursion _____ Location _____ Date _____

Operator Name _____ Motorcar Make _____ Railroad # (if available) _____

NARCOA Rule Book Certificate Number _____ NARCOA Current Insurance Number _____

Items	Pre-Inspection	Sat	Unsat	Rule
On Board				
Charged Fire Extinguisher 2 lb (ABC)				I-18
First Aid Kit				I-18
Two Orange or Red Flags (16" sq)				I-14
Current NARCOA Rule Book				II-10
Operable Flashlight				I-18
Compatible Tow Bar with Pins				I-10
Horn or Bell				I-16
Proper Brake Lever Travel				I-2
Front of Car				
Operable Front Headlight				I-12
Secure Front Hitch with 3/4" to 1" Hole				I-9
Safety Glass or Polycarbonate Windshields				I-3
Left Side of Car				
Left Brake Shoe Thickness - Front/Rear				
Brakes Properly Adjusted				I-2
Brake Cotter Pins Installed Properly				
Front Wheel Thickness and Profile				I-7
Rear Wheel Thickness and Profile				I-7
Axle Cotter Pins Installed - Front/Rear				
Rear of Car				
Working Rear Red Tail Light				I-12
Lever or Pedal Actuated Red Stop Light				I-13
Secure Rear Hitch with 3/4" to 1" Hole				I-9
Right Side of Car				
Right Brake Shoe Thickness - Front/Rear				
Brakes Properly Adjusted				I-2
Brake Cotter Pins Installed Properly				
Front Wheel Thickness and Profile				I-7
Rear Wheel Thickness and Profile				I-7
Axle Cotter Pins Installed - Front/Rear				
TurnTable - If Installed				
Table Retracts min. of 2.5" above railhead				I-19
Safety Lock on hydraulic turntables				I-19
Audible Warning Device				I-19
Optional - May not be required				
Mobile Radio				
USFS Approved Spark Arrestor				
Spare fuel secured properly				I-11
Chock or Chain				
Front & Rear Lift Handles				
Safety Vest/Shirt				

I understand that "At all times each operator has the ultimate responsibility for the safe condition of his/her motorcar beyond any of the specifics of the rules and standards". If allowed to operate in this excursion, I must correct any unsatisfactory items indicated in order to participate in future excursions. These safety checks are not designed to be overly restrictive, but are to insure a safe and enjoyable excursion for everyone.

I certify that I have inspected this motorcar and found it to meet all NARCOA standards as I have indicated on the Pre-Inspection column of this form and have determined that this motorcar is in a safe condition to operate on this excursion.

Operators Signature

Date

You will _____, Will not, _____, be allowed to participate in this excursion.

Reviewed by: _____ Date _____

of these on excursions.

Operable Flashlight: self-explanatory. But you need fresh batteries also. Do Not Assume! We do spot checks for working Flashlights.

Compatible Tow Bar with Pins: I like ¾" pins with 1" holes, they always fit. Remember, a Woodings has that heavy pipe ahead of the pinhole, and bars that fit Fairmonts seldom work over that Woodings pipe. Concerning tow bars, the rule reads "The ends of the tow bar shall overlap the top and bottom of the hitch" Bars that do not meet this requirement can not be used. The retaining clip that goes through the pin, can come loose, we tape the retaining clip to the pin to further secure it. When pushing a car, do so only until it is safe to tow it. Towing is the preferred method, as pushing introduces additional problems.

Horn or Bell: most operators over do this. But, it's better to be safe than sorry. Make sure your "noise" device is working properly.

Proper Brake Lever Travel: this depends on the car model, and manufacturer. Most cars should not move when the brake lever is in the first notch. Cars that have a variation of this need to be dealt with accordingly. Bring it to the EC's attention, if in doubt.

FRONT OF CAR

Operable Front Headlight: self-explanatory. I like two headlights, if one fails, there is a second.

Secure Front Hitch with ¾" to 1" hole: see tow bar discussion above.

Safety Glass or Polycarbonate Windshields: two-piece laminate glass, or a Poly type material with no major cracks. Be on the safe side, replace cracked or chipped glass.

LEFT & RIGHT SIDE OF CAR

Brake Shoe Thickness - Front/Rear: you are looking for full brake liner (cast iron) to steel wheel contact, with no brake shoe (wood block) showing where the brake liner contacts the wheel. If the brake liners are thin, replace them to keep your full braking function.

Brakes Properly Adjusted: this goes along with the brake lever holding the car in the first notch. If one side is tighter than the other, a brisk application of the brakes makes the car "jerk" to one side. It's not so easy getting them even, but it makes a difference when stopping.

Brake Cotter Pins Installed Properly: use of the correct fastener, and proper application of the correct fastener, is covered in the NARCOA Rules Book. Be sure to check all pieces.

Front & Rear Wheel Thickness and Profile: NARCOA has a minimum thickness requirement of 1/8 inch for light and medium weight cars, and 5/32 inch for heavy gang cars. The thinnest spot is usually at the flange. Use a set of wheel calipers (available from the NARCOA company store) to check the thickness in several places around the wheel. NARCOA has no specification for profile. However, for your car to track as designed, the profile needs to be taken into consideration. The wheel profile tool (also available from the NARCOA company store) will tell you if your wheel is "flat" and worn.

Axle Cotter Pins Installed - Front/Rear: it's not funny that I see a car or two each year without cotter pins, or with copper wire, and an assortment of other "retaining" material used. Check and insure that the correct retainer, a cotter pin, is installed.

REAR OF CAR

Working Rear Red Tail Light: at least one tail light also known as a marker light. This is not the stop light. Make sure the bulb is working. LED's seem to last a lot longer.

Lever or Pedal Actuated Red Stop Light: this is an easily overlooked item. Make sure the light comes on, and turns off when it is supposed to. Get the switch part number, so if it fails, you do not need to scramble for a replacement.

Secure Rear Hitch with ¾" to 1" Hole: same as front hitch covered above.

Turntable Retracts giving a minimum of 2.5" above railhead: BE SURE, this measurement is taken with the car on Rails. If you measure with car resting on flanges on a flat surface, you will need additional clearance. You must take the flange height into consideration.

Safety Lock on hydraulic turntables: turntables that retract using hydraulic pressure require a positive retaining mechanism to hold / lock the ram in the up, or travel position. Why? When the hydraulic pressure leaks off, the TT will drop. Remember, the pressure always leaks off ... count on it!

Audible Warning Device: NARCOA has added some additional information concerning alarms. They must be opera-

ble anytime the car is on RR property. This means no "cut out" switch stopping the unit from emitting an audible sound when the turn table is lowered on an excursion.

OPTIONAL

Optional gear may be required by the local club, excursion coordinator, or host railroad. This gear is announced in the meet listing, or materials sent out ahead of the event.

Mobile radio: capable of transmitting and receiving on the NARCOA frequency. Usually a hand radio, or simple scanner will not meet this requirement.

United States Forrest Service approved spark arrestor: will have USFS stamped on the part. This is often required on runs in the west.

Spare fuel secured properly: most clubs interpret this to mean your spare gas can must be inside the body of the car. See NARCOA rule 1.11 for more detail.

Chock or chain: use them when you stop to make sure the car does not roll.

Front & Rear lift handles: some clubs require these. Without them, rerailling a car is nearly impossible.

Safety Vest / Shirt: besides making you more visible when flagging, wearing one makes you look more professional to our railroad hosts. When buying a safety vest on the internet, look at the ones for surveyors. They have more pockets.

While the above is by no means, an in depth analysis of an inspection, it is meant to jog the operators memory. I am sure there are additions that can be added. Open discussion is encouraged, as the safer we operate, the better off the organization, and its members will be.

Tuning up the engine, lubrication, and general maintenance should all be done prior to "setting on." Get under, and around your car, poke it here and there, ask questions if you are not sure. Do all you can to not embarrass yourself at the excursion with a car that will not start, or has some problem with its mechanical equipment. Different models have different areas of failure, this should be taken into consideration during your extensive mechanical inspection. Ultimately, the readiness of the car is up to you the operator. You bear the final responsibility of operating a safe reliable car.

LOS PINOS

NARCOA BOARD APPROVES NEW RULES

ANNOUNCEMENT BY PRESIDENT WARREN RICCITELLI

The following items pertaining to the NARCOA book of rules were discussed by the board of directors at the annual meeting in Chicago on September 28 and 29, 2007. These tentatively approved changes and additions to the NARCOA book of rules were placed in the Nov/Dec issue of the Setoff for review of the membership. The period for comments has passed, and the Board of Directors has voted on final approval to each section.

RESULTS OF VOTE ON NEW RULES:

Area 1 – Riccitelli	YES
Area 2 – Williams	YES
Area 3 – Carpenter	YES
Area 4 – Falcon	YES
Area 5 – Moreman	YES
Area 6 – Brown	YES
Area 7 – Schneider	YES
Area 8 – Froese	YES
Area 9 – Springer	YES
Area 10 – Spicer	YES
Area 11 – Coleman	YES

These changes are now effective with publication in this issue of the Setoff and will be incorporated in the NARCOA Rule Book.

ITEM 1 INTRODUCTION

Add wording to the Introduction of the rulebook that states "The official operating language of NARCOA is English."

ITEM 2 Section I MOTORCAR MECHANICAL STANDARDS 11. FUEL TANKS

Auxiliary containers must be approved by a recognized testing agency for the purpose of storing and transporting fuel. Auxiliary fuel containers must be secured to the car. Protection against puncture for the main and auxiliary tanks is highly recommended.

ITEM 3 Section I MOTORCAR MECHANICAL STANDARDS 19. TURNTABLES.

Hydraulic turntables, including OEM Fairmont turntables, must be equipped with a positive locking mechanism that will prevent the table from dropping inadvertently. All turntable installations, including electrically operated turntables with positive gear engagement, must be equipped with a functioning audible warning device that notifies the operator if the turntable is not fully retracted. The turntable, when fully retracted, must be a minimum of two and one-half inches (2.5") above the railhead when the motorcar is sitting on the track.

ITEM 4 Section II MOTORCAR OPERATING RULES 20. OPERATOR CERTIFICATION/ INSURANCE.

All persons operating a motorcar or hy-rail vehicle on any NARCOA insured excursion must have successfully completed the NARCOA rulebook examination, obtained a NARCOA Certificate of Examination, have current NARCOA liability insurance coverage through the NARCOA insurance program, and (if they joined NARCOA after June 1, 2005) have been or are in the process of being mentored in accordance with the NARCOA operator mentoring program. All persons operating a motorcar or hy-rail vehicle on any NARCOA insured excursion must have a current Certificate of Examination card and a current NARCOA insurance card in his/her possession. (Exception: persons designated by the railroad on which the excursion is being run who are in the performance of their duties as railroad liaison / escort.)

ITEM 5 Section II MOTORCAR OPERATING RULES 22. TOWING OF MOTORCARS, TRAILERS, OR OTHER EQUIP-

MENT
Whenever practicable, other motorcars, trailers, or other on-track equipment that needs to be towed must be pulled and not pushed. This would apply to movements either forward or backward. If it is necessary to push another motorcar, trailer, or other on-track equipment; it shall be done at a speed no faster than 10 mph and for the shortest distance possible to a point where the towing vehicle can be placed in front of the other equipment. Equipment being pulled or pushed must be coupled to the assisting motorcar with an approved tow bar, tow hitches, and pins. The operator of a motorcar being towed should be prepared to assist with braking as necessary.

When an unoccupied piece of equipment or a piece of equipment that does not have independently operated brakes is being towed there shall be a safety chain applied between the motorcar and the equipment in addition to the above mentioned tow bar. The safety chain shall be a minimum of 3/16 inch proof chain with a working load capacity of at least 500 lbs. The chain shall be secured to a frame member or equally firm portion of the motorcar and equipment being towed and shall be so applied as to not create a hazard by hanging down or dragging the ground such as by wrapping excess length of chain around the tow bar.

ITEM 6 Section IV RULES FOR EXCURSION COORDINATORS 4. OPERATOR CERTIFICATION/ INSURANCE.

Excursion Coordinators, or their designee, must verify before the excursion departs the point of origin that all operators have a current NARCOA approved certificate of examination, have valid NARCOA insurance, and (if they joined NARCOA after June 1, 2005) have been properly mentored in accordance with the NARCOA operator mentoring program.

CUMBRES

POSTING EXCURSIONS ON THE NARCOA WEB PAGE

Excursion Coordinators must send event notices to webmaster@naroca.org. Here are a few do's and don'ts.

DO: Include dates of the event. State where the event starts (is that Franklin, North Carolina or Franklin, Ohio). Official name of the RR. Name of the affiliate hosting the event. Set on location and times. Give the exact street address for those of us with a GPS. Run schedule with dates and morning safety meeting times. Total miles. Optional equipment that is required such as radios. Name of Excursion Coordinator. Number of cars. Cost of the event. Contact person for registration. Link to a club website for more detailed information such as hotels. Do your own spell checking. Send all your information in the body of an e-mail as one paragraph (like this one) without tabs, bold type faces, or other formatting. That will make Keith Mackey's "cut and paste" job easier, and get your listing posted faster.

DON'T include a lot of details like how good the restaurant is, or the history of the line. Don't e-mail a flyer. Extract what you want, and send it as e-mail text. Don't specify the names of the days of the week as this has a high error rate. Only give the dates. Don't include the web master in blanket e-mail announcements. Send a specific announcement to the web address. Keith never posts anything that has not been sent specifically for publication.

CALL FOR SETOFF ARTICLES

Thank you to all the members who have provided materials for this issue of The SETOFF. As you read along, please take a moment to check their bylines and photo credits. The deadline for the July/August edition is June 6, 2008 (a little early, because your editor is leaving for a run). Please send items to setoff@ix.netcom.com. Articles should be in Word format files with a .doc extension. Photos should be sent as separate attachments to e-mail in .jpg format. Please do not paste photos into word documents.

- Editor

A-4-E TURNTABLE PLANS

There is very little documentation about the Fairmont turntables made for the heavier A cars. The only drawings your Editor has seen are in the rare "A8 Series C" Bulletin 892A. In that publication the drawing of the turntable is a side view only with hardly enough detail



Photos by Jamie Haislip

to identify parts. The exploded view of the hand operated hydraulic pump is well done, but again is only good enough for identifying parts. Today, any inquiry to Fairmont for technical information is answered by someone who most likely was not there when motorcars were being manufactured. Fairmont's employees have pride in the company's past products and history, but they have no experience or resources with which to answer our questions.

Anyone wanting to restore and operate A cars in the hobby really needs to solve the turntable problem. As Jim Spicer points out, the portable turntable made of two rails, and a center pivot beam is not suitable for setting on at a road crossing. An under car mechanism of some kind is necessary.

The two drawings on the following pages were made using an original A-4 turntable as the model. The OEM turntable used a hand operated pump to lower the plate and thus raise the car. The weight of the car and the action of the springs are used to retract the mechanism

back to the storage position. This design has some compromises. Due to the limited space under the car, a double action hydraulic cylinder would be too large.

So, Fairmont used a single action hydraulic cylinder, and relied upon springs for final retraction of the mechanism. One good thing, the springs keep the

mechanism retracted even if the hydraulic system is breached. If you delete the springs, you'll need a mechanical lock. Nevertheless, this is Fairmont's basic design, and as such is the starting point for building your own turntable. Use the drawings carefully. Decide for yourself if the information and materi-

als are useful and correct for your application. Remember that Fairmont appears to never have made two turntables alike.

Thanks go to the anonymous member who did the drawings on the next two pages. He had an A-4 turntable from which he took measurements. He wishes to remain anonymous because, although

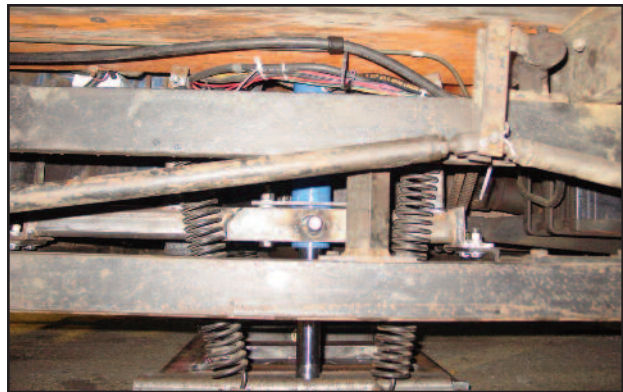

he can accurately draw any actual object he has in front of him, he does not consider himself an expert on turntables. Jamie Haislip and Mark North used the drawings as the basis to make two A-4 turntables. Thank you Jamie for the photos, and the introduction to the CAD expert. - Editor

COXO

FAIRMONT A - 4 - E TURNTABLE - NOT VERIFIED

PLATE ONE - FOOT ASSEMBLY

USER MUST DECIDE THE UTILITY AND ACCURACY OF DIMENSIONS & MATERIALS

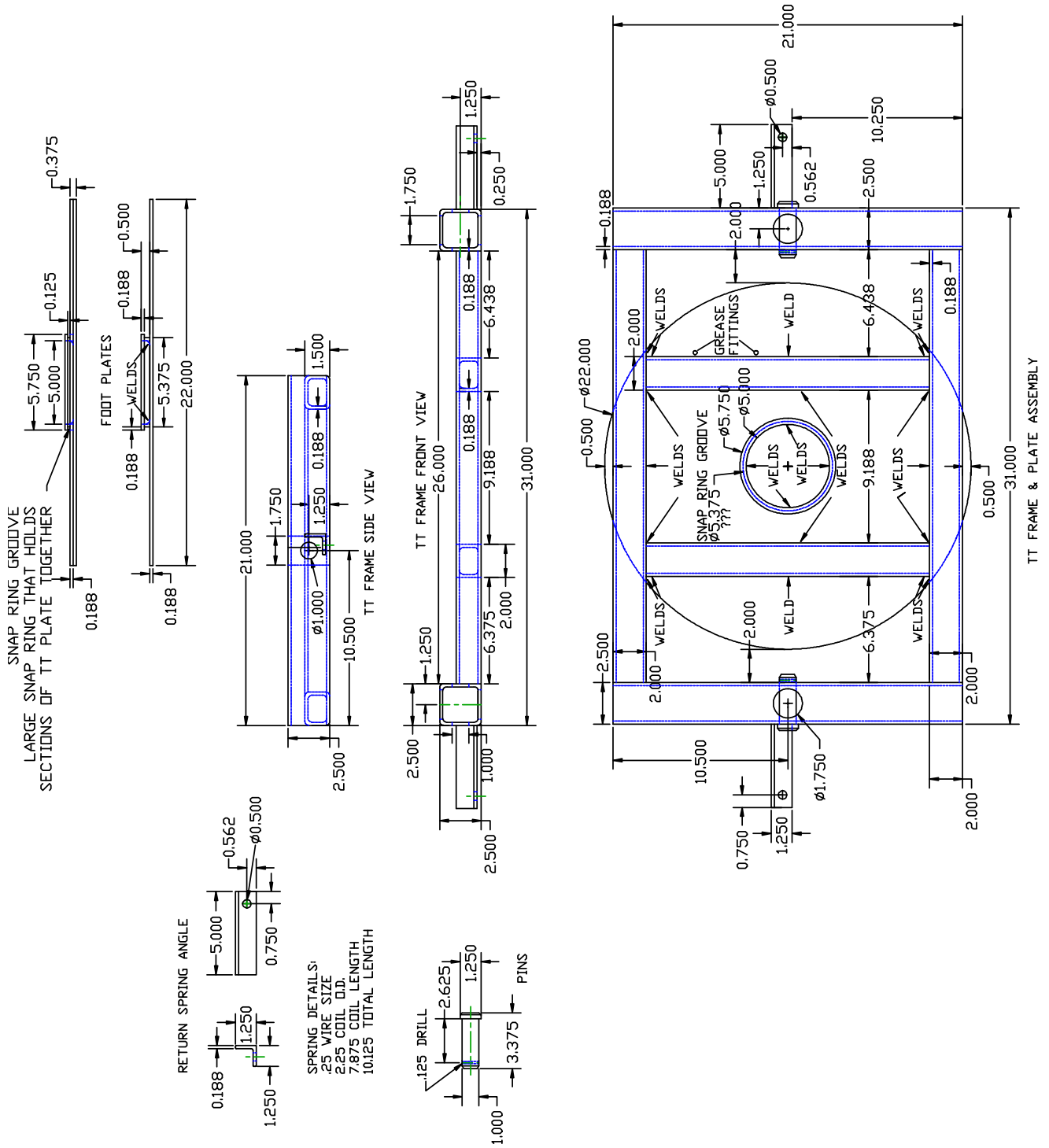

FAIRMONT A - 4 - E TURNTABLE - NOT VERIFIED

PLATE TWO - PISTON & BRACKET DETAIL

USER MUST DECIDE THE UTILITY AND ACCURACY OF DIMENSIONS & MATERIALS

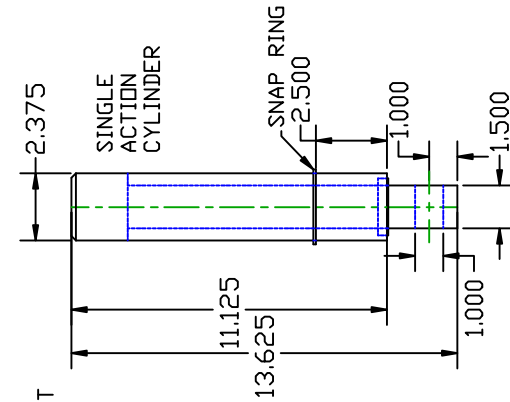
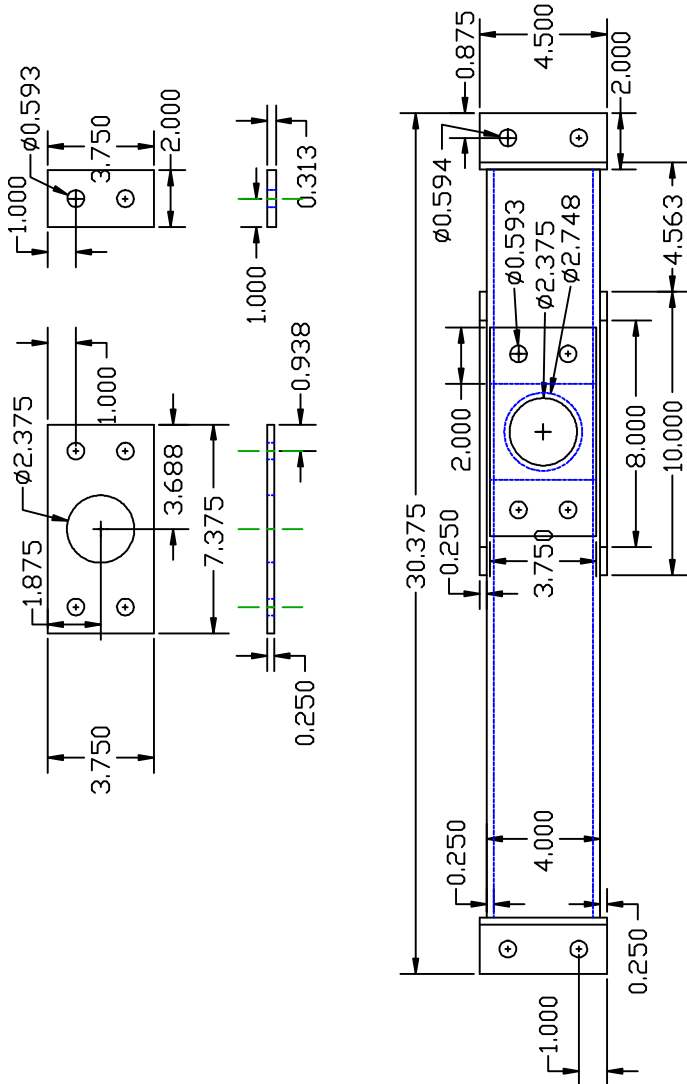

CYLINDERS ARE 13.625 RETRACTED & 20.625 EXTENDED, 7.000 STROKE/LIFT

NOTE: TOTAL WEIGHT OF CAR WHEN LIFTED IS SUPPORTED ON THE TWO SNAP RINGS LET INTO EXTERIOR CYLINDER WALL.

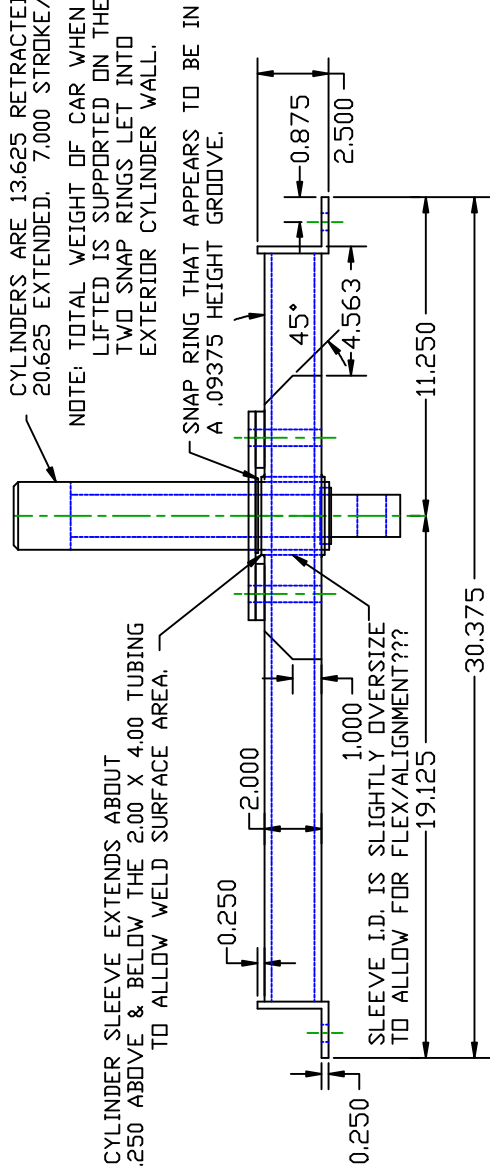

TURNING FAIRMONT GANG CARS

SURVEY OF TURNTABLES AND OTHER SOLUTIONS

BY JIM SPICER

So now you got that big sucker on the track, but it's headed the wrong way. Hopefully, I can help you figure a way to turn it around. This is not a "How To" article. I simply want to supply you with enough information to get you started doing some research.

and the hydraulic lift. Both types have their advantages and disadvantages.

The advantage of the push/drive on is: there are some available, they work pretty well, and no modification to your car is required except some brackets to carry them.

taken when turning. If the turntable (TT) is installed away from the balance point the car can be quite heavy on one end and require several people to help turn it.

Some owners have installed a hard point or jack point near the balance point and lift the car with a floor jack. Again the down side is having to balance the car and turn. The up side of all these meth-



The OEM portable turntable consists of two rails, a truss, and a support base. The long rails are carried either on the deck of the car or on side brackets. The rails have holes for inserting a bolt to adjust the balance point. With some care, this turntable can turn any motorcar, large or small.

Photos by Jim Spicer unless noted.



You need to be able to turn your car with just you and your on board passengers. Asking others on the excursion to help lift and turn a heavy car will soon make you very unpopular. Help is generally available for turning but not for lifting. There are several methods you can use to turn heavy gang cars besides just plain muscling them around. Fairmont provided two types; the push/drive on

The disadvantages are the car is balanced on the turntable center beam and requires some care to maneuver around. . Because of the center beam design, the car cannot be turned at a crossing. The disadvantage is most apparent when setting on at a right angle crossing.

The hydraulic type (*at right*) is difficult to find. They have a hand pump which is easy to operate but takes time. If the hand pump has been replaced with a 12V electric hydraulic pump, then it's just a matter of pushing a button to lift your car. Because of the location of the transmission, the assembly may not be exactly at the balance point. They also have a small pivot point so care must be



Above is an A-6/8 OEM turntable. It mounts vertically and uses the socket in the center to rotate on a half ball on a board placed on ties or crossing at the center of the car. The car is then turned on the half ball. No bearing just grease / friction on the half ball. Below is an A-4-E TT that has a base plate the car rotates on. Both TT's have single acting cylinders and use springs for the return.



Photo by Ed Best

ods is no physical lifting of a heavy car.

Another down side is they do have some risk when not turned carefully. Usually the turn is made on ballasted track with ballast sloping away at tie ends. Stepping over the rail then walking through loose ballast can cause tripping

that attaches to rear of his car. He used a trailer tongue jack with wheel attached. Cranking lifts the rear of car, then it can be pushed around without manual lifting. The down side is it is slow, has to be used on a level hard surface, and it does take some effort to turn. The up side is it re-

a Reese 5th wheel camper hitch. He purchased the disc and camper jacks at Camping World.

Before attempting to build or fit any permanent turntable to your car there are two things you must do. NARCOA rules state there must be 2 1/2 inches clearance between rail head and bottom of TT. You must carefully measure the distance from rail head to bottom of your transmission. You need more than the required 2 1/2". When retracted the bottom plate will be under the transmission. If you don't have nearly three inches you must figure out a way to get that amount.

You might be able to raise the engine/transmission assembly just enough to give you the required amount. Next you must find the balance point (BP) of your car. This gives you the point to work toward so your car will balance properly when lifted off the rails. To find the BP, lift one end of car, placing blocks approximately in the center, then put a piece of angle iron on the block. A few moves and you will have it balanced. Mark it with chalk then record in your notes exactly how far it is from an axle to the BP. (See photo below).

Building a TT for a Fairmont A car is not as simple as pulling out a drawing and spending some afternoon whipping one out. It appears that Fairmont didn't build two cars exactly alike unless on the same order. Each engine/transmission combination has a different under side profile.

Finally, never do anything to compromise your car's brake system. Motor-cars only have one means of stopping. If you modify it and it fails, you are in big trouble.

In the next Setoff we will delve into principal of a "better" turntable based on the Beaver Cars.

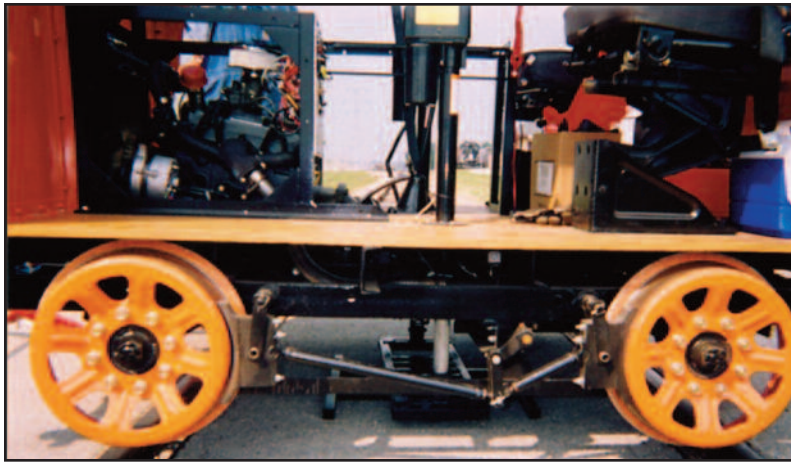

Photos by Dale Brix



quires no physical lifting, and on a level hard surface it cannot get away.

Dale Brix designed and built a system for turning his A-3. I find Dale's concept innovative and surprisingly simple. It is a whole different approach and solves the problem of the transmission being in exactly the wrong place.

Dale installed two camper jacks at the balance point on

on rail or having the ballast roll under your foot. I have seen cars tilt precariously, sometimes to the point of losing it. One good helper is far better than a group. If there are several inexperienced helpers they tend to fight each other.

Ed Best designed and built a jack and wheel arrangement (previous page)

his car. He built a simple turntable he places between the rails. He then rolls the car over the portable TT, and lifts his car with the camper jacks. I have never seen him turn, but he says it is easy to center up and turn. The plus is, it works anywhere including when setting on at a crossing. He places two light channel irons across the track to make the car easy to move and line up with the portable TT. The portable TT appears to not be excessively heavy. For a bearing Dale uses a 10" Mylar disc from



Determine the center balance point.

...never do anything to compromise your car's brake system.

CRESCO

NARCOA INSURANCE PROGRAM HISTORY

BY TOM NORMAN, NARCOA INSURANCE ADMINISTRATOR

I'm busy processing liability insurance program applications for the 2008 policy year. I've mailed out over 810 insurance cards to date, and the 3/31/08 cut off date is fast approaching. That means I only have another 150 to 200 applications to go! I've been volunteering to handle the insurance since 1995, and have seen quite a few changes over the years. I thought maybe members would be interested in a little history.

NARCOA has had a liability policy covering NARCOA and the member since in 1989. Over the years, we have gone through at least nine different insurance companies: Kemper, Transamerica, Reliance, General Accident, USF&G, Lloyds, Admiral, Essex, and Darwin. Railroad liability coverage is not something that is handled by a lot of companies. Most of the company changes over the years were due to the company's decision to exit the railroad liability business. One of the companies declared bankruptcy. Coverage amounts have varied from \$1,000,000 in 1990 to our current \$10,000,000 per each occurrence limit, with a \$20,000,000 general aggregate limit.

Participation by NARCOA members initially was 526 in 1995. That number has steadily risen to 983 in 2004. In 2005 we saw our first decrease to 961, and to 932 in 2006, before gaining in 2007 to 984. The decrease in 2005 was due to my failure to negotiate a new policy with Lloyds before the end of our policy year. Insurance coverage was not in place until May 1st, and I think that put a damper on member's participation. Premiums per member have varied from \$105 to as high as \$187 per year for insurance. I feel that our current premium of \$150 is a good value for the member.

Beginning March 6th 1995 we started issuing Certificates of Insurance to host railroads. These certificates add the host railroad to our policy as an additional insured. At policy year-end I summarize these and submit them to the insurance company. Through 1/31/08 NARCOA issued 2,061 certificates to 414 different railroads. We average

around 158 certificates per year. Last year we issued 154 certificates to 99 railroads, of which 23 were new host railroads.

The Certificates of Insurance are processed by the Area Insurance Representatives. They include Hank Brown, Jim McKeel, Doug Stivers, Tom Falicon, Dick Wilhelm, and me. The reps are appointed by the NARCOA Insurance Administrator. Each rep has a region that they cover, which helps spread the insurance workload around. The rep is responsible for sending Certificates of Permission to excursion coordinators. The Certificate of Permission is the form that the railroad signs, approving an excursion. The rep confirms that the ex-

cursion is being planed by a certified excursion coordinator, and sponsored by a NARCOA approved affiliate. The rep also verifies that the excursion is posted in The Setoff, and /or listed on the NARCOA website, before issuing the Certificate of Insurance.

Over the past years NARCOA members have paid over \$1,200,000 in premiums to the insurance carriers. Our claims have only totaled around \$40,000. This is a very good loss ratio, and now that NARCOA has at least 14 years history of liability insurance coverage, I hope that we can negotiate a lower premium in future years. Remember everyone ---- be safe out there.

FARMRAIL IN OKLAHOMA

BY DRAKE RICE

Clinton, OK - The Oklahoma Railway Museum (ORM), a NARCOA affiliate, hosted a two day run on Farmrail in western Oklahoma January 19 and 20, 2008. The first day was from Clinton to Okeene, OK, and back, on the old Frisco line for a total of 126 miles. The second day was on the former Santa Fe Orient line from Sentential to Altus, OK, and back for a total of 71 miles.

warmed up, everyone was able to run. On the second day, the temperature at set-on was 22 degrees and no problems were encountered.

The trips were through the rolling hills in north central Oklahoma and through the flat southwestern part of the state except for the Cut through the Granite mountains at Lake Lugert. ORM and NARCOA appreciate Farmrail for letting



January 20th, the group pauses at Lugert Cut in the Granite Mountains along Altus-Lugert Reservoir in southwest Oklahoma.

Photo by Drake Rice

Eight motorcars, 2 Hy-Rails, and 15 members participated in the event. The first day at the start the temperature was 11 degrees and a couple of the cars had problems with moisture freezing in the fuel lines, but when the units were

us enjoy their system and being a supporter of the Oklahoma Railway Museum.

LOBATO

117 MEMBERS PASS THE EXCURSION COORDINATORS TEST

THE THREE MOST MISSED QUESTIONS ANSWERED HERE

BY HANK BROWN, CHAIRMAN - OPERATIONS COMMITTEE

Thanks go to all the excursion coordinators that took the EC test recently. We had an excellent turnout and the results were amazing. The average time it took a member to complete the test was 2 hours. Some members took up to 4 hours, which meant everyone was looking for the correct answers. All the questions were taken from the Operations Handbook, Rule book, the NARCOA Website, or the Policy Handbook. The Board of Directors gave us the responsibility of creating the test at the board meeting last September. Most of them took the test prior to it being mailed to the current existing coordinators. The goal of the Operations Committee was for all excursion coordinators to pass the test with a perfect score, with an unlimited number of tries. Even if an excursion coordinator missed only one question, the committee wanted that member to know where to find the correct answer. So, the test was re-done until a perfect score was achieved.

Here are the three questions, in the

CALL FOR CALENDAR PHOTOS

The deadline for photos for the 2009 calendar is October 15, 2008. In general, photographs taken in the last year are desired. Electronic submissions are preferred. Send photos on CD to The SETOFF Editor by mail. Please mark the envelope "2009 calendar." Photo files must be high resolution with .jpg extensions. Printed photos are welcome only if the original negative is included. If requested, negatives will be scanned and returned. Otherwise, all materials are archived, and not returned. Please include caption information about who, what, when, where, and why for each photograph.

order of frequency, that were "re-done" the most.

Question 11 – "Who is ultimately responsible for the inspection of motorcars?" was the most missed question. In 2006 the Board of Directors was looking for a way to reduce the liability to the excursion coordinator and decided to put the responsibility of inspecting a motorcar on the owner where it belonged, instead of on the excursion coordinator or designee. However, it is still very important that an inspection of motorcars be done just prior to an excursion. This will help members look for things that they might have missed. Some of our affiliates use stickers to place on the windows of cars they have inspected. This helps reduce the number of cars that need a "hard" look at future excursions of theirs.

Question 1 – "Whose rules and regulations are the most important during an excursion?" I believe the reason this question was missed was the confusion between the railroad, and excursion coordinator position, and the way the rule book is written. However, if you review page 2 under RAILROAD RULES it states the railroad may impose their own operating rules. Where these rules and standards conflict with those in this rule book, the more restrictive rules in terms of the safety of individuals and the protection of property will prevail in all instances. Additionally, a railroad may specifically waive a NARCOA rule or rules in the interest of safety on its track. Remember we are guests of a railroad.

Question 9 – "Prior to each day of a motorcar excursion which 6 items should be mentioned at a safety meeting?" This question was designed to see what the excursion coordinator was saying at a safety meeting. The answer is in the Operations Handbook and the rule book, but is not clearly found. Therefore, we were trying to see what the excursion coordinator

was doing. It is the intention of the Operations Committee to revise the current handbook and collate the answers from each test to come up with a minimum standard requirement for a safety meeting. The answers given were very helpful. Most of the current excursion coordinators added their own information in addition to what was in the handbook.

Editors note: Here are the answers The SETOFF Editor gave to # 9:

1. Review track authority & discuss today's schedule
2. Review following distances
3. Grade crossing procedures
4. Breakdown rules, towing/pushing
5. Reverse movements
6. End of day set-off or tie-down procedures. Also, introduce the rail road escort, and have the escort make their desired comments. Elicit from the escort the location of spring or self guarded frogs, and other hazards.

The current list of certified excursion coordinators will be posted on the NARCOA website around the middle of February. If you do not see your name, chances are you didn't submit the test. I will be accepting tests throughout the year either by email at trainguyz@charter.net or by snail mail at

NARCOA
622 Oak Street
Cottage Grove, WI 53527

However, after February 29, 2008 anyone passing the test will have to be mentored even though you have been an excursion coordinator your whole life, unless the Board of Directors changes the rules. Again, I would like thank everyone that participated in this testing program. I think we now have a more informed group of 117 excursion coordinators.

CHAMA

NARCOA does not guarantee, certify or warrant that any mechanical equipment, modification, solution or device described in articles or advertisements in the SETOFF are safe or suitable for any member's needs or purposes. Technical articles are provided for members' consideration only. Readers are advised to do their own due diligence to determine the safety and suitability of any such equipment, modification, solution or device for their purposes, and are advised to seek outside expert advice.

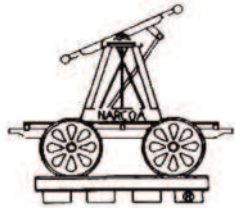

NARCOA EXCURSIONS AS OF APRIL 15, 2008

Please submit all excursions and ads directly to
webmaster@narcoa.org

The SETOFF downloads directly from the website
for the most current information.

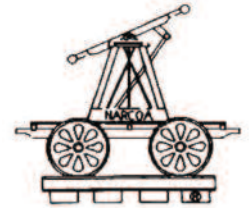

May 03, 2008 - TX posted 04/01

Texas State Railroad

A one day excursion of the Texas State Railroad has been rescheduled for Saturday May 3, 2008. We will operate from Rusk Texas to Palestine and will be operating along with the Railroads passenger trains. The trip will cover 50 miles round trip. This will be a NARCOA insured trip and all NARCOA rules will apply. All cars will be inspected and you must have a copy of your current rule book, 2008 insurance card as well as your Operators Certificate. You will be required to wear hard sole shoes (work boots) no exceptions. No home built cars will be allowed. The cost for this trip will be \$100.00/car which covers the railroad's fee. The registration deadline is April 26, 2008. The coordinator for this trip will be John von Briesen 713-689-4184 Email - mt19a2fm@verizon.net To register for this trip send this form along with your check made payable to: John von Briesen 10 Oak Court #3207 Houston Texas 77006

May 03, 2008 - ON posted 03/27

St. Thomas and Eastern Railway

NARCOA-insured motor car excursion on the 34 mile St. Thomas & Eastern railway will take place on Saturday, May 3, 2008. We will set-on in Tillsonburg, Ontario beginning at 9 AM with an eastward departure scheduled for 10 AM. We will make at least one round trip (68 miles) and possibly more, if time permits. The cost of the run will be \$60.00 Canadian or \$65.00 U.S. This is a NARCOA insurance run ONLY and all NARCOA rules will be in effect. This run is presented by Kenneth Annett-an individual member NARCOA affiliate. To register, please make a check payable to: "Kenneth Annett" and send to: Motorcar Run, 3483 Church Street, Windsor, Ontario, Canada. N9E 1V6 kannett@mnsi.net

May 03, 2008 - PA posted 03/01

Everett Railroad

This will be our eighth year of coordinating rides on this railroad. In the previous seven trips, the runs totaled about 60 miles each. We expect nearly the same in 2008. The set-on is at Claysburg, PA which is located just off I-99 between Altoona and Bedford, PA. We will travel north to Hollidaysburg, turn the cars and travel south to Roaring Spring's Railroad station, where we will take our lunch/restroom stop. Lunch will be available at the station. Details will be sent to those who register. The station's restroom and a portable toilet will be available. After lunch we will continue south to Martinsburg, back through the wye to turn the cars, and retrace our route back to Claysburg. This excursion will be a great way to start the weekend for those riding the Central PA Excursion's ride on the Nittany & Bald Eagle RR on Sunday May 4. This will be a Northern Central Railcar Assoc. excursion. NARCOA rules will be in effect. There is a limit of 40 cars. Cost is \$45 per car. An application can be downloaded from our web site: <http://wilmingtonnrhs.com/ncra/> Contact: Gary Shrey, 54 Adams Road, New Freedom, Pennsylvania 17349 Phone: 717-227-9628 E-Mail: GShrey@aol.com

May 04, 2008 - PA posted 02/09

Nittany & Bald Eagle Railroad

Central Pennsylvania Excursions is pleased to sponsor a 1 day run on the Nittany & Bald Eagle Railroad - Ride the approximately 70 miles RT of the Nittany & Bald Eagle Railroad from Bellefonte to either Tyrone or Mill Hall and return if track is available. If not, we will ride the Bellefonte Secondary. The exact itinerary will be set by the railroad that day due to train traffic. Former Pennsylvania Railroad, lots of welded rail. Proof of NARCOA insurance required, all NARCOA rules will be enforced. Registration fee - \$55.00. Note: All CPE rides are rain or shine. No cancellations due to weather or schedule changes. Hard soled shoes required, no sneakers or sandals. Children must be closely supervised at all times. Send

check to: Central PA Excursions, PO Box 145, White Deer, PA 17887. Questions: (570) 538-9050 or email firefighter5@jlink.net. Note - Saturday will be a ride on the Everett RR.

May 10 - 11, 2008 - WA posted 02/19

Eastern Washington Gateway RR.

Pacific Railcar Operators is pleased to announce a motorcar excursion over the Eastern Washington Gateway RR (a division of U.S. Rail Partners) May 10-11, 2008. Set on will be at Wilbur, WA. On Saturday May 10th we will run Wilbur to Cheney and return (152 miles round trip). This day will include a visit to the site of the Inland Empire Railroad Historical Society's new museum at Reardan and an activity on site. Sunday May 11th we will travel Wilbur to Cooley City and return (72 miles round trip). The run east of Wilbur will be through the Eastern Washington scablands formed by the great Lake Missoula floods during the last ice age 15,000 years ago. All participants must have 2008 NARCOA insurance and current NARCOA operator's cards. PRO membership is encouraged. All NARCOA rules and guidelines are in effect. Spark arrestors are required on all cars. Packets with itinerary, lodging (RV) and restaurant information will be mailed upon receipt of payment. Run fee for the weekend is \$215.00. Please make checks payable to PRO, but mail them to Jim Morefield, 1037 Richardson, Lewiston, ID 83501. For more information contact Co-Excursion Coordinators Jim Morefield, (208) 743-0802 jmorefield@ca-bleone.net, Bill Taylor (406) 721-2351 wtaylor@bresnan.net or Steve Healy (253) 630-9817 healy.v.s@gmail.com.

May 17 - 18, 2008 - AL/MS posted 12/15

Columbus and Greenville RR - Luxapalila Valley RR - Greenville Port Authority RR

Saturday - Greenwood, MS to Greenville, MS 110 miles RT This is our first trip on these beautiful railroads. Saturday will be a combination of the Columbus and Greenville Railroad and the Greenville Port Authority Railroad. We cross the Mississippi Delta on top of one of the great Mississippi Levys overlooking the Mississippi Port of Greenville, MS. Our Saturdays set-on location is the origin of W.C. Handy's first Blues song, "Where the Southern Crosses the Dawg" in Moorhead, MS.. Sunday - Belk, Alabama to Steens, MS 52 miles RT Sundays run will be down through the beautiful Luxapalila Valley, following the winding Luxapalila River from Belk, AL all the way to Steens, MS. We will depart from Kennedy, AL. You must be a Narcoa member, have Narcoa insurance, and have passed the rules test. All operators and passengers must wear a safety vest/shirt while on railroad property. There is plenty of parking for your autos, truck, trailers, and RVs. A mobile VHF radio is strongly encouraged. The cost for both wonderful days is \$150.00. There is a maximum car limit of 35 cars. No refunds after April 17, 2008 unless I can find another car from the waiting list to take your place. Please make your checks out to Atlanta Railcar Transportation LLC, c/o Bobby Moreman - EC, 3520 Cold Springs Ln, Chamblee, GA 30341-2036. Click here for a brochure. A confirmation letter will follow the receipt of your check. moreman@mindspring.com More info at <http://salebranch.nfshost.com/motorcar/>

May 23 - 24, 2008 - CA posted 03/17

Amador Foothill Railroad

Motorcars Operators West and the Recreational Railroad Coalition presents the Ione Railfair and Vintage Motorfest. This is a two day event on the Amador Foothill Railroad in Ione, California. Participants will run a grand total of 100 miles on five roundtrip excursions including a Saturday night sunset run. The run fee is \$55 per car and early registration would be appreciated. Set-on will begin at 3:00 pm Friday, 23rd of May and there is RV parking on site @\$10 per vehicle. The Railfair will include displays of Antique RXR equipment from the California State RXR Museum and the

RRC. Also, there will be displays of antique agricultural equipment, an operating miniature Railroad, an antique bus and a Concord Stagecoach. A Saturday evening tri-tip dinner will be served and the cost is \$15. This is a Narcoa insured excursion, and all Narcoa rules will apply. For Railfair details contact Dave Balestreri, 2320 "E" street, Sacramento, Ca.. (H.916-444-6374, C.916 531 7536) email dbalestreri@softcom.net

May 24, 2008 - IA posted 01/15

Iowa River Railroad

Eldora, Iowa - The First Iowa Division will host a ride on this ex-M&StL line which runs from Marshalltown to Steamboat Rock, Iowa and north past the ethanol plant towards Ackley. Mileage could be about 70 miles round trip depending on how far we can ride. We plan on possibly riding the line twice if time permits. Cost of this ride is \$45 per car. The set on time will be at 7:00am with an 8:00am departure. The set on location is about 2 blocks north of the Hwy 175 crossing. Motels in Eldora are the Village Motel (641-939-3441) and the Eldora Motel (641-939-2232). Both of these motels are small and family-owned so there is a limited number of rooms at each so make your reservations early. Dave Pratt (515-674-3803) is the Excursion Coordinator for this ride. Contact Carl Schneider at 515-967-5181 or e-mail motorcarl@mchsi.com for more information. This is a Narcoa-insured ride and all Narcoa rules apply.

May 24 - 26, 2008 - CO updated 03/18

Creede Branch, Denver & Rio Grande Railway Historic Foundation

South Fork-Creede, CO - 8th Anniversary and Tune Up Run. The Rocky Mountain Division invites you to celebrate the 8th anniversary of the purchase of the Creede branch by the D&RGHF from the Union Pacific, returning the Rio Grande name to this historic, and scenic property. This is a great low key run for mentoring new operators, and a great run to see how your car runs in the mountains. The entire branch may not be accessible due to post winter track conditions, but we will arrange the run to travel somewhere between 60 to 80 track miles during these dates. Speeder limit for the run will be 25 Cost: \$110 (\$100 is a tax deductible donation). Checks should be made to "Rocky Mountain Division". NARCOA rules and insurance will be in effect. Spark arrestors will be required. Jon Keeling will be EC. Contact Philip Walters, PO Box 57, Mancos, CO 81328 (970) 533-7177 or pwalters@frontier.net Details and updates at http://www.rockymountaindivision.com/creede_8th_anniv.htm

May 24 - 26, 2008 - ID updated 04/13

Camas Prairie Railroad - FULL - Waiting List Only

Pacific Railcar Operators is pleased to announce the third annual Memorial Day Weekend motorcar excursion on three branches of the former Camas Prairie Railroad (CSP) on May 24, 25 and 26, 2008. The initial set on point will be at the headquarters of the Great Northwest Railroad in East Lewiston, Idaho. A waiting list will be maintained on a first come - first served basis and late entries will be notified of their status on the waiting list. Run fees for the weekend are \$295 and no refunds will be issued after May 1, 2008 unless the vacancy can be filled from the waiting list. Make checks payable to Pacific Railcar Operators and mail them to Meet Coordinator Steve Taulbee, 2206 Burrell Avenue, Lewiston, ID 83501.

May 24 - 26, 2008 - CO posted 02/09

Leadville, Colorado & Southern RR.

The Rocky Mountain Division would like to invite you to the Leadville, Colorado & Southern RR for a three day Opening Weekend Celebration. This excursion starts in Leadville, CO and continues up above tree line at 11,000ft, near Freemont Pass and the worlds largest Molybdenum mine at Climax. Come ride with us on the old Colorado & Southern roadbed and experience the life above 10,000ft. This can be a demanding climate to be in. Please be aware of "Mountain sickness". This can effect folks who are coming from "Down Below". Weather changes can happen very quickly here also. Please be prepared. NARCOA Insurance is required by all motorcars. All NARCOA rules will apply. Forest Service approved spark arrestors REQUIRED. Cost: \$100 per motorcar. Lodging and food are on your own. Contact: Gus Mocilac gus_mary@comcast.net

May 28/29, 2008 (Wed-Thur) - Old Maine Central - Mountain Division/Conway Scenic Railroad.

Join us with this old favorite. From Redstone to Sebago Lake we will travel

this line that has been out of service for ever twenty years. There are a few paved over crossings, but all are passable. An added event will be a stop at a railroad museum on the way. RT mileage is about 80 miles. No "A" cars or hy-rails allowed because of track conditions.

On Thursday will travel the **Conway Scenic Railroad** one of the most beautiful railroads in the country will be our host for a trip thru Crawford Notch, the Willey House and Frankenstein Trestle. The scenic journey will offer beautiful views of the White Mountains, the Presidential Range and Mt Washington. RT Mileage is about 88 miles. Seton will be at Redstone. Seton and hotel info to be forwarded upon reservation. Fee for both days is 175.00. Listed CEC is Warren Riccitelli. For more information contact Warren Riccitelli (401) 232-0992 or warren.riccitelli@verison.net or Al Elliott at ((732) 536-7460.

May 30, 2008 (Fri) - "The Railroad to the Moon..." With many requests from people running the Conway Scenic excursions, we have worked a special deal with the **Mt. Washington Cog Railway**. Established over 100 years ago, this is the oldest cog railroad in the world, and still runs on coal. The 37.4% grade offers no match for the best motorcars. We will be passengers for this 2 ½ trip. This will offer plenty of time to get to the Hobo for the Friday chicken barbeque. Fee is 32.50 per person. Listed CEC is Warren Riccitelli. For more information contact Warren Riccitelli (401) 232-0992 or warren.riccitelli@verison.net or Al Elliott at ((732) 536-7460.

May 30 - June 1, 2008 - NH posted 01/15

Hobo Railroad

Paul G. Yorkis is coordinating the 20th Anniversary Hobo Railroad Track Car Meet 2 day run over the Hobo and Winnepesaukee Scenic Railroads May 30, 31 and June 1, 2008. This is the oldest continuous track car meet in the United States. Participants will travel approximately 95 round-trip miles between Lincoln, NH and Weirs Beach, NH on Saturday and approximately 50 miles round-trip on Sunday between Tilton, NH and Weirs Beach, NH. This event is open to all operators with the Hobo Railroad Timetable, State of New Hampshire Operating Rules, and NORAC rules applying. Every crew member is required to wear a safety vest. All cars will be inspected each day. The event fee of \$75.00 per car includes one car, operator and crew member. Optional costs include meals, shirts, vests, hotel, and fees for additional crew members. There is no car limit at this time. This is a NOT a NARCOA insured event. For trip details contact Paul G. Yorkis, 7 Independence Lane, Medway, MA 02053. Tel: 508-533-4848 between 7:00 PM and 9:00 PM or email: pgyorkis@aol.com.

May 31, 2008 - CA posted 04/10

California Northern RR

PRO is pleased to announce their annual Tracy to Los Banos Woolgrowers/Apricot Festival run on Saturday, May 31. The cost of this run is \$120 per car. The cost for lunch at the Woolgrowers is \$17.00 per person. Please make your check payable to PRO and mail it to Steve Paluso, 2878 Rosario Court, San Jose, CA 95132. Please include a self-addressed, stamped envelope with 58 cents postage. Since the tracks in Los Banos end about 3 miles away from the Woolgrowers we have made arrangements for transportation to the Woolgrowers and back. If you have any questions, you can email Steve at sbpaluso@aol.com or call between 1:00 pm to 7:30 pm at (408) 956-8070. No calls after 7:30 please. We need a 20 car minimum to make this run happen. Deadline for signing up is May 22.

May 31, 2008 - GA posted 03/29

Blue Ridge Scenic Railroad

Blue Ridge, GA to Talking Rock, GA - Approx 55 miles round trip. Picnic Lunch in Talking Rock. NARCOA rules apply. Set on Blue Ridge at Fire Station, South of Depot, at 8 AM, Safety Briefing at 9 AM. Do not set on until permission is given by EC. Price: \$5.00 per car active Blue Ridge Scenic Railroad Volunteers. All others \$10.00 per car. Coordinators: Carl Hymen (706-455-0492, Scottie Wershing (828) 644-5204, Ron Long (706) 632-9736. Email: aherron@tds.net

June 1, 2008 - CA posted 04/05

Sierra Railroad

Sierra RR Oakdale to Jamestown, California and return. Run held in conjunction with Steve Paluso's Saturday May 31st PRO Woolgrowers

run to Los Banos on the California Northern. Cost \$140.- per car. Please send your check made out to Motorcar Operators West, include current NARCOA numbers and a LSASE envelope before May 21st to: Chris Ogilvie 6676 Colton Blvd. Oakland CA 94611 (510) 339-1071 home (415) 896-2644 office cwogilvie@sbcglobal.net 20 car minimum. All NARCOA licenced and insured operators are welcome! NARCOA and MOW rules will apply.

June 7, 2008 - PA posted 02/09

Lycoming Valley Railroad

Central Pennsylvania Excursions is pleased to sponsor a 1 day run on the Lycoming Valley Railroad – Ride the 80 miles RT of the Lycoming Valley Railroad from Williamsport to Muncy and Avis. Former Reading and New York Central Railroads. Proof of NARCOA insurance required, all NARCOA rules will be enforced. Registration fee - \$55.00. Note: All CPE rides are rain or shine. No cancellations due to weather. Hard soled shoes required, no sneakers or sandals. Children must be closely supervised at all times. Send check to: Central PA Excursions, PO Box 145, White Deer, PA 17887. Questions: (570) 538-9050 or email firefighter5@jlink.net

June 8, 2008 - PA posted 02/09

Union County Industrial Railroad

CPE is pleased to sponsor a 1 day run on the Union County Industrial Railroad NOTE - THE TRACK FROM LEWISBURG TO MIFFLINBURG HAS BEEN LISTED FOR ABANDONMENT AND MAY BE TORN UP BY JUNE. THIS MAY BE THE CHANCE TO RIDE ON THIS 10 MILES OF TRACK. Ride the 25 miles RT of the Union County Industrial Railroad from New Columbia to Winfield, Mifflinburg and back. Former Reading and Pennsylvania Railroad. Proof of NARCOA insurance required, all NARCOA rules will be enforced. Registration fee - \$30.00. Note: All CPE rides are rain or shine. No cancellations due to weather. Hard soled shoes required, no sneakers or sandals. Children must be closely supervised at all times. Send check to: Central PA Excursions, PO Box 145, White Deer, PA 17887. Questions: (570) 538-9050 or email firefighter5@jlink.net

June 7 - 18, 2008 - AK posted 08/15

Alaska Railroad FULL - Waiting List

Motorcar Operators West is pleased to announce the Alaska Railroad Excursion for June 7, 2008 through June 18, 2008. The excursion will take motorcar operators and guests from Anchorage to Seward to Denali National Park to Fairbanks and return. Cost of the excursion is \$5500 which includes railroad, lodging, bus shuttle, fuel, and affiliated fees. This is a NARCOA insured excursion, and all NARCOA rules will apply. For trip details please contact Dan Berg, 2017 Mule Creek Rd, Las Vegas, NV 89134 (702) 341-8617 or email: dabajb@anv.net

June 12 - 18, 2008 - MT updated 02/13

Big Sky Adventure FULL - Waiting List

Pacific Railcar Operators is pleased to announce its Big Sky Adventure II June 10-16, 2008. Participants will run over 5 different branches of three unique railroads in Montana's Big Sky Country. They are Montana Rail Link, Butte, Anaconda & Pacific (Rarus), and Central Montana Rail Inc. Certified Excursion Coordinator Bill Taylor, 917 Parkview Way, Missoula, MT 59803. For more information call (406) 721-2351 or email wtaylor@bresnan.net

June 13 - 17, 2008 - CO posted 12/18

First Iowa Division June Tour - Colorado

The Colorado tour cost is \$475 with \$100 tax deductible. A complete information packet will be sent to those signing up. Contact Dave Pratt (515-674-3803) or Carl Schneider (515-967-5181) or e-mail motorcarl@mchsi.com for further information.

June 13 - San Luis & Rio Grande Railroad - Alamosa to Monte Vista, Colorado & San Luis Central Railroad - Monte Vista to Center, Colorado This ride will be a late afternoon and evening trip. Total miles for this run will be 66 miles.

June 14 - San Luis & Rio Grande Railroad - Alamosa – LaVeta, Colorado We will ride from Alamosa east over LaVeta Pass at 9242'. This will be a total of 152 miles for the day.

June 15 - Denver & Rio Grande Scenic Railroad - South Fork – Creede, Colorado, There will be one round trip on this line for a total of 44 miles

for the day.

June 16 - 17 - Leadville & Southern Railroad - Leadville to Climax, Colorado We will set on the evening of June 16th for a night run up the mountain on this scenic line which goes up to 11,300 feet at Climax and then return to Leadville. We will then depart Leadville on the morning of the 17th for a daytime run back up the mountain to Climax and returning to Leadville in time for the excursion train to run. Mileage is 11 1/2 miles each way and very scenic so bring lots of film.

June 18 & 19 - Travel Days for those participating in the Idaho/Washington Tour. NARCOA-insured and all NARCOA rules will apply.

June 14, 2008 - MI posted 02/22

Minnesota Southern Railroad

The First Iowa Division is hosting a ride on the Minnesota Southern at Luverne, Minnesota. Set on will be at 6:30am and we will travel east through Magnolia, Adrian, and Rushmore with a turn around at Agate Junction with the Union Pacific near Worthington. Upon our return to Luverne, we will stop for lunch on your own. Total mileage is 90 miles for the day. Cost of this ride is \$30.. There is a Super 8 motel (507-283-9541) in Luverne. There is also a Comfort Inn (800-228-5150) in Luverne. Dave Pratt (515-674-3803) is the Excursion Coordinator for this ride. Contact Carl Schneider at 515-967-5181 or e-mail motorcarl@mchsi.com for more information. This is a Narcoa-insured ride and all Narcoa rules apply.

June 14 - 15, 2008 - IN posted 04/06

Hoosier Valley Railroad Museum

The HVRM will be giving public train rides during the North Judson, Indiana Mint Festival Days. Operators who participate with the festival will be asked to give rides to the general public for Sat. and or Sun. Set on: 7:00 to 9:00am (CENTRAL TIME). Exact schedule for rides will be sent as time approaches. Operators will have a private late afternoon run to LaCrosse or Malden on Sat. and a possible LaCrosse run on Sun. morning if schedule permits. NO CHARGE. All cars have the option of being stored in the engine house on Friday & Sat night. All NARCOA rules and regulations apply. Limit of 20 cars. A-cars welcome and are accepted for private runs. HVRM insurance will cover public rides. NARCOA insurance covers private runs. Camping on grounds is permitted and Friday arrivals welcome. For registration and all extra information "hotels and restaurants" Contact Jon Schmidt, 17591 w15b Rd. Culver, IN 46511 (574-842-2948) or email: irishpaddy44@hotmail.com Please send Rule Book and Insurance number when registering. Museum site. hvrm.railfan.net for more info and directions.

June 15, 2008 - NC posted 03/03

Great Smoky Mountains RR

Tom Falicon would like to announce a NARCOA insured excursion on the Great Smoky Mountains RR in North Carolina. Set-on will be in Andrews, NC and we will make two runs over the Red Marble Gap Grade with one run going as far as Bryson City if time and train movements permit. On our first trip over the mountain, two cycle cars will be able to try their luck at mastering the 5+% grade if they like! Total round trip miles will be a minimum of 60 miles and a max of around 90 miles. Cost of this trip is: \$85.00. For a sign-up form and more info, contact: EC, Tom Falicon, 1227 Sawmill Creek Rd., Bryson City, NC 28713, 828-488-8063, rail-dawg@gte.net

June 21, 2008 - GA posted 03/29

Blue Ridge Scenic Railroad

Blue Ridge, GA to Ellijay, GA – Approx 30 miles round trip. Supper stop in Ellijay. NARCOA rules apply. Set on Blue Ridge at Fire Station, South of Depot, at 4 PM, Safety Briefing at 5 PM. Do not set on until permission is given by EC. Price: \$5.00 per car active Blue Ridge Scenic Railroad Volunteers. All others \$10.00 per car. Coordinators: Carl Hymen (706-455-0492, Scottie Wershing (828) 644-5204, Ron Long (706) 632-9736. Email: aherron@tds.net

June 21 - 22, 2008 - WV updated 02/02

West Virginia Central RR FULL - Waiting List

Appalachian Rail Excursions is pleased to announce a motorcar run on the West Virginia Central in Elkins West Virginia for June 21-22, 2008. Set on is at the Western Maryland Depot. For more info and registration: EC

- Paul S. Rujak Phone:304-670-4099, 786 Hudson Hill Road E-mail: psrujak@weir.net Weirton, WV 26062-5584

June 20 - 30, 2008 - ID/WA posted 12/18

First Iowa Division June Tour - Idaho/Washington.

Cost of the Idaho/Washington tour is \$585. A complete information packet will be sent to those signing up. Contact Dave Pratt (515-674-3803) or Carl Schneider (515-967-5181) or e-mail motorcarl@mchsi.com for further information.

June 20 - 22 - Camas Prairie (Now Bountiful Grain & Craig Mountain Railroad) - Lewiston, Idaho We will start this trip with a night run beginning at Lapwai which is east of Lewiston. This ride is 26 miles round trip. Day 2 will also begin at Lapwai and will consist of a 104 mile round trip to Kamiah and return. The third day will begin at Craigmont and travel down the mountain to Culesac and return uphill back to Craigmont. This line has tunnels and high bridges including Half Moon Trestle. Mileage is about 40 miles round trip and we may be able to make this run twice if time permits.

June 23 - Washington & Idaho Railroad - Pullman, Washington We will start our trip in Pullman and travel north to Marshall, WA. The cars will be turned and return to Palouse where we will ride east through Potlatch to Harvard and then return to Pullman. This ride is 212 miles round trip.

June 24 - 25 - Wallowa Union Railroad - Joseph, Oregon There will be a night run of 30 miles round trip through the rugged canyons along the banks of the Grande Ronde and Wallowa Rivers. Mileage for this ride is 128 miles round trip.

June 26 & 27 - Travel & Rest Days

June 28 - St. Maries Railroad - St. Maries to Clarkia, Idaho This is a 152 mile round trip ride through some very beautiful scenery in Idaho. The tracks go over bridges, through tunnels, and logging camps following the St. Maries River.

June 29 - Pend Oreille Railroad - Cusick, Washington to Dover, Idaho This ride will take us 84 miles round trip along the Pend Oreille River over the Tacoma Creek Bridge and over a trestle that spans the Fox Canyon Dam.

June 30 - Pend Oreille Railroad - Cusick to Metaline Falls, Washington For our final day of this tour, we will riding along the Pend Oreille River to Metaline Falls. Mileage for this run is 84 miles round trip. NARCOA-insured and all NARCOA rules will apply.

June 23 - 27, 2008 - AB/SK posted 01/14

Great Western Railway.

North Central Railcars, Ltd. is pleased to announce a 5-day motor car excursion on the Great Western Railway in the rolling hills of southern Saskatchewan. This trip will follow the CN/ANY excursion in Alberta and includes some new GWR mileage. The trip will run between Assiniboia and Ogema (the former Red Coat Road and Rail), Assiniboia and Coronach, SK (ex-CP Fife Lake Sub) and between Assiniboia and Consul, SK. The trip will cover approximately 600 rail miles. The excursion fee of \$325 (CDN) or \$350 (USD) covers the railroad fee and miscellaneous excursion costs. Participants will need to make their own lodging arrangements in Assiniboia (June 22, 23 & 24) and Shaunavon, SK (June 25 & 26). For those interested in making the trip, please contact the excursion coordinator for a list of potential hotels. Registration materials and complete trip details, itinerary, and maps will be sent upon receipt of the excursion fee. This is a NARCOA insured excursion and NARCOA rules apply. There is a 25 car limit. To register, send a check for \$325 (CDN) or \$350.00 (USD) (payable to North Central Railcars) to Michael P. Ford, 7712 Carpenter Court, Plainfield, IN 46168-8035. For questions or further information, contact Mike at (317) 839-9320 or via e-mail (mford@indy.rr.com).

June 26 - July 10, 2008 - BC/OR/ID updated 03/04

Pacific Northwest Tour.

Verdant Valleys, Massive Mountains and New Rail - MOW is pleased to sponsor a TWELVE day tour including nine railroads in the Pacific Northwest: Kelowna Pacific Railway (Vernon, BC) June 27 - 29, Okanagan Valley Railway (Vernon, BC) June 28, Kootenay Valley Railway (Nelson, BC) July 1 - 4, and Canadian Pacific Railway July 2 - 3, Idaho Northern RR and Wallowa Union RR (La Grande, OR) July 6 & 8, Idaho Northern RR (Fruitland, ID) July 9-10 and Modoc Northern RR (Lakeview, OR) July 12. Participants will travel approximately 1060 miles on 9 railroads

and approximately 990 road miles starting in southern British Columbia. MOW membership not required. All participants must have 2008 NARCOA Insurance and current license number. Estimated trip fee of \$1600.00 per car. Participants are responsible for their own meals and lodging. There is a 25-car limit. This is a NARCOA insured excursion, and all NARCOA rules will apply. For registration information and trip details visit the MOW website or (after Feb. 6) contact Margaret Hope (604) 320-7613 mail to: mhope@lionsgate.ca

July 4, 2008 - CO posted 12/19

San Luis & Rio Grande RR (LaVeta Pass) July 4th BBQ run. The Rocky Mountain Division invites you to: Set-on at LaVeta, CO and travel over the pass to Blanca, Co a distance of 42 miles. BBQ and meet with SLRG passenger train at Fir. Return to LaVeta the same day. NARCOA rules and insurance will be in effect. Speeder limit will be 25 Cost: \$125.00 per speeder. Sweeps, wheel chocks, spark arrestors will be required. Jon Keeling will be EC. Contact Philip Walters, PO Box 57, Mancos, CO 81328 (970) 533-7177 or pwalters@frontier.net

July 4 - 6, 2008 - WV posted 03/24

Petersburg WV Railshow

Appalachian Rail Excursions LLC is pleased to announce that we will again take part in the annual Rail Show at Petersburg WV July 4-6, 2008. Needed are ten participants to give rides to the public during the show. All proceeds go to WV Operation Lifesaver Kids Rail Camp. All cars and operators must be NARCOA Compliant. Participants must be available to set-on on Friday July 4 and be able to stay until approx 4PM on Sunday July 6. Standard size cars only. For more info Contact John Gonder at UP3706@msn.com

July 5 - 6, 2008 - CO posted 12/19

Creede Branch, Denver & Rio Grande Railway Historic Foundation. Days of '92. The Rocky Mountain Division invites you to: Set-on at South Fork, CO, travel to Creede, CO, a distance of 23 miles, then return to South Fork. The run will be the same on both days NARCOA rules and insurance will be in effect. This will coincide with the Creede Colorado "Days of '92" mining events and celebration. Speeder limit will be 25 Cost: \$125.00 per speeder for one day, \$200 for both days. Spark arrestors will be required. Jon Keeling will be EC. Contact Philip Walters, PO Box 57, Mancos, CO 81328 (970) 533-7177 or pwalters@frontier.net

July 11 & 13, 2008 - ID posted 03/26

Washington and Idaho Railroad.

Pacific Railcar Operators is pleased to announce the WI&M / P&L branch excursion on Friday, July 11 and Sunday, July 13, 2008 on the Washington and Idaho Railroad. The set on point will be at the depot in Potlatch, Idaho. On Friday, we will travel from Potlatch to Palouse on the former WI&M railroad and then from Palouse on the former Palouse and Lewiston branch of the Northern Pacific Railroad to Marshall and return, a total of 138 miles. Sunday's trip will again travel from Potlatch to Palouse and then we will turn our cars and go to the end of the track near Moscow, Idaho and return for a total of 74 miles. On Saturday, operators will have the opportunity to participate in the Potlatch Depot Days benefit at no additional charge. Railroad fees for the two days are \$125 and no refunds will be issued after July 7th, 2008. Make checks payable to Pacific Railcar Operators and mail them to Steve Taulbee, 2206 Burrell Ave. Lewiston, ID 83501. NARCOA insurance, NARCOA Rules certification, PRO Membership, spark arrestors and mechanically sound motorcars with all the specified NARCOA equipment is required. Packets with itinerary, motels, camping spots and maps will be mailed after payment is received. 30 car limit. For more information, contact Meet Co-Coordinator Steve Taulbee, (208) 743-5430, taulbee1@cableone.net or Jim Morefield, (208) 743-0802, jmorefield@cableone.net.

July 12, 2008 - ID posted 03/26

PRO "Potlatch Depot Days" Benefit.

Pacific Railcar Operators is pleased to announce its fifth annual "Potlatch Depot Days" Benefit Saturday July 12, 2008 on the Washington & Idaho Railroad (former WI&M) at Potlatch, ID. This will be held in association with a PRO excursion over the remainder of the W&I (former NP P&L) on Friday and Sunday, July 11th and 13th. That excursion is listed separately.

Saturday participants will be asked to give rides to Potlatch Depot Days participants over eight miles of track. Profits go to the Washington, Idaho & Montana Ry Historical Society and its continuing efforts to restore the Potlatch depot. There will be no charge for participating in Saturday's event, but please notify the coordinator if you are attending. Information letters will be sent with lodging and set on information on receipt of your notification. All NARCOA rules and guidelines are in effect. Spark arrestors are required. For more information call Excursion Coordinator Bill Taylor at (406) 721-2351 or email wtaylor@bresnan.net Mail notification to 917 Parkview Way, Missoula, MT 59803.

July 19, 2008 - IA posted 01/15

Appanoose County Railroad

Centerville, Iowa - The First Iowa Division announces a ride on the Appanoose County Railroad. Set on will be at 6:30am just south of the water tower in the southeast part of town with an 8:00am departure. We will travel 35 miles north to Albia on parts of the ex-Rock Island Golden State Route, ex-Burlington, and the ex-Wabash line to Des Moines. This line also crosses the IC&E Kansas City - Quad Cities mainline. Cost of the ride is \$35. Motels are the Super 8 (800-800-8000) and Motel 60 (800-437-7271). Dave Pratt (515-674-3803) is the Excursion Coordinator for this ride. Contact Carl Schneider at 515-967-5181 or e-mail motorcarl@mchsi.com for more information. This is a Narcoa-insured ride and all Narcoa rules apply.

July 19-20, 2008 - CO posted 02/09

Leadville, Colorado & Southern RR.

The Rocky Mountain Division would like to invite you to the Leadville, Colorado & Southern RR. When it's hot down below, head to the top of the Rockies! This excursion starts in Leadville, CO and continues up above tree line at 11,000ft, near Freemont Pass and the worlds largest Molybdenum mine at Climax. Come ride with us on the old Colorado & Southern roadbed and experience the life above 10,000ft. This can be a demanding climate to be in. Please be aware of "Mountain sickness". This can effect folks who are coming from "Down Below". Weather changes can happen very quickly here also. Please be prepared. NARCOA Insurance is required by all motorcars. All NARCOA Insurance is required by all motorcars. All NARCOA rules will apply. Forest Service approved spark arrestors REQUIRED. Cost: \$70 per motorcar. Lodging and food are on your own. Contact: Gus Mocilac gus_mary@comcast.net

July 19, 2008 - NY updated 04/08

New York Susquehanna & Western Railway, Utica Branch

The Volunteer Railroaders Association is pleased to sponsor a 1-day run over the NYS&W Utica Branch July 19, 2008. Participants will travel approximately 84 round-trip miles between Sherburne, NY and Utica, NY. Operators and riders under 18 are not permitted by the railroad. The trip fee is \$80.00 per car which includes the railroad's per car fee. There is a 40 car limit. This is a NARCOA insured excursion, and all NARCOA rules will apply. This is a non-mentoring run. ECs for the trip are KC Smith and Chris Vitz. For trip details contact the VRA at 80 Royal Avenue, Hawthorne, NJ 07506 Tel: (973) 238-0555 or email to: volunteerra@yahoo.com. You can also sign up and pay for the trip with a major credit card via our website at <http://www.vratrips.org>

July 20, 2008 - NY Confirmed date - updated 04/08

Cooperstown & Charlotte Valley Railroad

The Volunteer Railroaders Association is pleased to sponsor a 1-day run over the Cooperstown & Charlotte Valley Railroad July 20, 2008. Participants will travel approximately 30 round-trip miles between Cooperstown Junction, NY and Cooperstown, NY. Lunch will be on your own in downtown Cooperstown, NY. Ample time will be provided for a lunch break and a visit to the Baseball Hall of Fame. We will be stopping at convenient locations for bathroom breaks. Operators and riders under 18 are welcomed by the railroad. The trip fee is \$30.00 per car which includes the railroad's per car fee. There is a 20 car limit. This is a NARCOA insured excursion, and all NARCOA rules will apply. Mentoring will be permitted on this run via pre-arrangement. ECs for the trip are KC Smith and Chris Vitz. For trip details contact the VRA at 80 Royal Avenue, Hawthorne, NJ 07506 Tel: (973) 238-0555 or email to: volunteerra@yahoo.com. You can also sign up and pay for the trip with a major credit card via our website

at <http://www.vratrips.org>

July 26-27 - Upper Hudson Railroad (NY)

Nestled in the lower Adirondicks in upstate New York, NERCA will again ride the Upper Hudson Railroad which we last rode about eight years ago. Located north of Albany, this ride follows the scenic head waters of the Hudson River. Our seton will be in North Creek on Saturday and Corinth on Sunday. Saturday the Upper Hudson Railroad's beautiful museum and gift shop will be opened for us. Total RT mileage is 94 miles with two-thirds of it be ridden each day. Excursion fee is \$150 and included the indescribable buffet at the 1000 Acres Dude Ranch on Saturday. For more information, contact Warren Riccitelli @ (401) 232-0992 or warren.riccitelli@verizon.net. or Al Elliott at ((732) 536-7460.

July 26 - 27, 2008 - PA posted 02/09

North Shore & Shamokin Valley Railroads.

Central PA Weekend - CPE is pleased to sponsor a 2 day run on the North Shore and Shamokin Valley Railroads-- Saturday, July 26th, ride the 86 RT miles of the North Shore Railroad from Northumberland to Berwick and back. Former Erie Lackawanna Railroad. Sunday, July 27th ride the 50 miles RT of the Shamokin Valley Railroad from Sunbury to Mt. Carmel Junction and back. Former Reading and Pennsylvania Railroads. Saturday night dinner and tour at the Central PA Chapter NRHS White Deer Train Station. \$10 of the registration fee donated to the chapter. Sunday tour of the Lower Anthracite model railroad while in Shamokin. Proof of NARCOA insurance required, all NARCOA rules will be enforced. Registration fee - \$70.00. Note: All CPE rides are rain or shine. No cancellations due to weather. Hard soled shoes required, no sneakers or sandals. Children must be closely supervised at all times. Send check to: Central PA Excursions, PO Box 145, White Deer, PA 17887. Questions: (570) 538-9050 or email firefighter5@jlink.net

July 28 - 31, 2008 - ON posted 03/05

Algoma Central Ry

Great Lakes Railcars is pleased to sponsor a 4-day motorcar excursion over the line of the Algoma Central Railway (ACR) on July 28 through July 31, 2008. All NARCOA members are welcome to participate. The excursion will cover the 585 mile entire ACR line from Sault Ste. Marie to Hearst, Ontario. The trip will start from the ACR Steelton Yard in Sault Ste. Marie and overnight in Wawa and Hearst during the four day trip. The excursion fee of US\$1350 includes all railroad fees, overnight accommodations (3 nights) in Wawa and Hearst, bus transportation between Hawk Junction and hotel in Wawa, box lunch for 3 days (Tues., Wed., Thurs) and motorcar fuel. Complete Registration Package with all details will be sent upon receipt of the excursion fee. This is a NARCOA insured excursion and all NARCOA, Grea Lakes Railcar and Railroad rules will apply. To register, send a check for \$1350 (Payable to Great Lakes Railcars) to: Fred D. Lonnes, Excursion Coordinator, P. O. Box 92, Western Springs, IL 60558-0092, email: algoma.2008@flash.net

August 02 , 2008 - WV posted 02/06

South Branch Valley Railroad

A.R.E. would like to invite you to ride the SBV over a 102 mile RT route through the scenic Potomac River Valley of West Virginia from Petersburg to Greensprings and return. We will ride through the famous "TROUGH" to see Bald Eagles. and a beautiful river gorge. We will meet the Potomac Eagle Scenic Train and stop a Romney for a break at the Wapacomo Station then on to Greensprings to turn and return to Petersburg. All NARCOA rules apply. A.R.E. requires over the ankle hard soled shoes(work boots) at all times while on RR property. 40 car limit. Trip Fee is \$65.00 for more info contact: John Gonder, Appalachian Rail Excursions LLC, 415 Levine Lane, Ruffs Dale, PA 15679 1512, 724-696-4544 6-8Pm only up3706@msn.com

August 03 , 2008 - WV posted 02/06

Western Maryland Scenic Railroad.

Join us in August 2008 as we again ride this scenic mountain railroad. Sseton at the engine house in Ridgeley, WV. Approximate round trip mileage will be 34 miles. This excursion will be a great way to complete the weekend for those riding the SBVRR excursion on Saturday August 2. This will be a Northern Central Railcar Assoc. excursion. All NARCOA rules will be enforced. All cars will be inspected. There is a 40 car limit. Price for this

excursion is \$40 per car. An application can be downloaded from our web site: <http://wilmingtonnrhs.com/nrcr/> Contact: Gary Shrey, 54 Adams Road, New Freedom, Pennsylvania 17349 Phone: 717-227-9628 E-Mail: GShrey@aol.com

August 16 - 17, 2008 - CO posted 02/09

Leadville, Colorado & Southern RR.

The Rocky Mountain Division would like to invite you to the Leadville, Colorado & Southern RR. When it's hot down below, head to the top of the Rockies! This excursion starts in Leadville, CO and continues up above tree line at 11,000ft, near Freemont Pass and the worlds largest Molybdenum mine at Climax. Come ride with us on the old Colorado & Southern roadbed and experience the life above 10,000ft. This can be a demanding climate to be in. Please be aware of "Mountain sickness". This can effect folks who are coming from "Down Below". Weather changes can happen very quickly here also. Please be prepared. NARCOA Insurance is required by all motorcars. All NARCOA Insurance is required by all motorcars. All NARCOA rules will apply. Forest Service approved spark arrestors REQUIRED. Cost: \$70 per motorcar. Lodging and food are on your own. Contact: Gus Mocilac gus_mary@comcast.net

August 18 - 24, 2008 - CO/NM updated 02/04

Cumbres & Toltec RR & Durango & Silverton RR - SOLD OUT

2008 NEW MEXICO/COLORADO 36" NARROW GAUGE TOUR on the C&TS, Cumbres & Toltec Scenic Narrow Gauge Railroad and the D&SNG, Durango & Silverton Narrow Gauge Railroad in New Mexico and Colorado. Patrick "Smitty" Smith, An Individual Affiliate & EC. NO mentoring at this event. Trip fee of \$675.00 per car. There is a 20 motorcar limit. Contact Smitty, 20799 Sumpter Stage Hwy., Baker City, OR. 97814-7753 Phone # 541-524-9428 e-mail smitty@oregontrail.net

Answer to railroad puzzle: Cumbres & Toltec Scenic NG Railroad. Stations are listed East to West.

August 23/24 - NY - Finger Lakes Railway

As always, the Finger Lakes is going to be of those runs that we try to make a little differt each year. For the past two years we have offered night runs to the old Army Base in Kandaia. And we have had request to see what it looks like during the day. Saturday morning you will have your wish. And in late morning we will head for Cayuga Lake and the same BBQ as last year. Well venture out to Auburn and back for a rest in Geneva before our 'night run' to the Army Base. Sunday, we will run from Geneva to Victor on the new track that the Finger Lakes started operating last year from the Ontario Central to Victor, NY. Included will be a box lunch from the BBQ caterer. Meet fee is 175.00. RT miles is 58 on Saturday an 60 miles on Sunday. Listed CEC is Warren Riccitelli. For more information contact Warren Riccitelli (401) 232-0992 or warren.riccitelli@verison.net or Al Elliott at ((732) 536-7460.

August 30, 2008 - MO posted 02/20

Ft. Leonard Wood Army Base RR

Ft. Leonard Wood, Missouri The First Iowa Division has set up a ride on the Army base at Ft. Leonard Wood, Missouri. Set on will be at 10:30 am with a 12:00 noon departure. As you enter the fort from I-44, be in the left lane and pull into the inspection area by the security check point. You will have to go in the visitor center before proceeding through the vehicle check point. Have an early lunch or bring snacks along as there won't be a stop for lunch. We will make two trips on this 20-mile scenic line through the Ozarks to the connection with the BNSF at Bundy Junction. Due to security issues, everyone will need a picture ID, vehicle registration, proof of insurance, and be prepared for a vehicle inspection. Cost of this ride is \$30. Dave Pratt (515-674-3803) is the Excursion Coordinator for this ride. Contact Carl Schneider at 515-967-5181 or e-mail motorcarl@mchsi.com for more information. This is a Narcoia-insured ride and all Narcoia rules apply.

August 31, 2008 - MO posted 02/20

Colt Railway

Columbia, Missouri Come join us on this First Iowa Division ride which runs northeast from Columbia to Centralia on an ex-Wabash track. We will set on beginning at 6:30 am and have a scheduled 8:00 am departure for the first run. Our set on location is at Boone County Mill Works which is

located in downtown Columbia. Take the Rangeline Rd. exit from I-70 and drive south to the T intersection with Rogers St. Turn left and the set on is about a half block in the Boone Co. Millworks facility. We will run this line two times during the day. Each run is approximately 44 miles round trip so we will have a total for the day of about 88 miles. Cost of this ride is \$40 per car. Dave Pratt (515-674-3803) is the Excursion Coordinator for this ride. Contact Carl Schneider at 515-967-5181 or e-mail motorcarl@mchsi.com for more information. This is a Narcoia-insured ride and all Narcoia rules apply.

September 12 -14, 2008 - MI updated 02/09

Great Lakes Central RR FULL - waiting list only.

Great Lakes Railcars, Inc. is pleased to announce a 3-day motor car excursion on the Great Lakes Central Railroad (ex-TSBY) in Michigan's Lower Peninsula. This excursion will cover some track not previously traveled. The trip will start in Clare, MI and run south to Ithaca and return on Friday, then northwest to Traverse City on Saturday, with return to Clare on Sunday. The entire trip will cover approximately 275 miles. The excursion fee of \$375 covers the railroad fee, overnight accommodations for 1 night in Traverse City (Sat., Sept. 13, 2008), ground transportation in Traverse City, and other miscellaneous excursion costs. Registration materials, complete details, itinerary, and maps will be sent upon receipt of the excursion fee. This is a NARCOA insured excursion and NARCOA rules apply. There is a 25 car limit. To register, send a check for \$375.00 (Payable to Great Lakes Railcars) to Michael P. Ford, 7712 Carpenter Court, Plainfield, IN 46168-8035. Mike at (317) 839-9320 or via e-mail (mford@indy.rr.com).

September 13, 2008 - CA posted 04/10

Sierra RR

Oakdale to Jamestown and return. The cost of the run is \$140 per car. Please send your check payable to PRO to Steve Paluso, 2878 Rosario Court, San Jose, CA, 95132 with a SASE. If you have any questions, you can email Steve Paluso at sbpaluso@aol.com or call (408) 956-8070 between 1:00 pm - 7:30 pm. Please no phone calls after 7:30.

September 13 -14, 2008 - WA posted 03/21

Pend Oreille Valley Authority Railroad.

Pacific Railcar Operators is pleased to announce an excursion on the Pend Oreille Valley Authority Railroad September 13-14, 2008 in conjunction with Newport, Washington's "Pend Oreille County Heritage Days." Saturday morning the excursion begins on POVA's Newport-Dover section which was once a part of the Great Northern main line built in 1892 (58 miles round trip). We will return around noon. Saturday afternoon participants are asked to help give rides to residents participating in the Heritage Days event at the Newport Depot. Sunday the excursion will continue on POVA's Newport-Metaline Falls section operated by the Milwaukee Road until 1980 and built by the Idaho, Washington & Northern (124 miles round trip). The cost of the excursion is \$125. Preference will be given to those who participate in the Heritage Days activity. Limit 30 cars. Total track mileage will be approximately 162 miles. All NARCOA rules and guidelines are in effect. Spark arrestors are required. Make checks payable to PRO, and mail them to Co-excursion Coordinator Bill Taylor, 917 Parkview Way, Missoula, MT 59803. No reservations accepted without payment. Fees are non-refundable after September 1st. For more information call (406) 721-2351 or email taylor@bresnan.net or Co-Excursion Coordinator Bob Shanklin at bobvi@conceptable.com.

September 19, 2008 - CO posted 12/19

Creede Branch, Denver & Rio Grande Railway Historic Foundation

The Rocky Mountain Division invites you to: Set-on at South Fork, CO, travel to Creede, CO, a distance of 23 miles and return to South Fork the same day. Speeder limit will be 25 Cost: \$125.00. NARCOA rules and insurance will be in effect. Spark arrestors will be required. Jon Keeling will be EC. Contact Philip Walters, PO Box 57, Mancos, CO 81328 (970) 533-7177 or pwalters@frontier.net Note: we are working on a run on the San Luis Central on September 20th for a run in between this run and the SLRG run on the 21st.

September 19 - 21, 2008 - NC posted 03/19

Great Smoky Mountains RR

This is our GSMR RAILFEST 2008 RUN where we give rides and display our cars during the three day festival and then ride our motorcars in the late afternoon/ early evening covering the entire GSMR line in segments over the three day period. Set-on will be in Bryson City, North Carolina. Total round trip miles for all days combined will be at least 100 miles. Come out and display your car and get to ride the GSMR at a reduced rate in mild weather. Cost for this three day event is: \$50.00. For a sign-up form or more info contact: E.C. Tom Falicon, 1227 Sawmill Creek Rd., Bryson City, NC 28713 Phone: (828) 488-8063 or email Raildawg@gte.net

September 19 - 21, 2008 - SD posted 03/18

Black Hills Central RR

Hill City, South Dakota. The Rocky Mountain Division invites you to the Fall 2008 Black Hills Central RR motorcar ride. Cost: \$45.00 per motorcar, 15 motorcar limit. Set on will be at 3:45 pm Friday, with a 6pm departure evening run to Keystone, SD. Keystone is approximately ten miles from Hill City. Saturday we will make two runs to Keystone during the day and Sunday we will have a morning run to Keystone followed by setoff. Total track mileage for this excursion will be approximately 80 miles. NARCOA Insurance is required by all motorcars. All NARCOA rules will be applied. Checks should be made out to "Rocky Mountain Division". Contact: Lynn French email- flf450@aol.com Mail- 38688 Indian Head Lane, Crawford, CO 81415 (970) 921-7700 More details can be found at http://www.rockymountaindivision.com/black_hills_2008.htm

September 20, 2008 - IA posted 01/15

Appanoose County Railroad

Centerville, Iowa - The First Iowa Division announces a ride on the Appanoose County Railroad. Set on will be at 6:30am just south of the water tower in the southeast part of town with an 8:00am departure. We will travel 35 miles north to Albia on a well-maintained combination of welded and jointed track. This line also crosses the IC&E Kansas City - Quad Cities mainline and we might see a train there. Cost of the ride is \$35. Motels are the Super 8 (800-800-8000) and Motel 60 (800-437-7271). Dave Pratt (515-674-3803) is the Excursion Coordinator for this ride. Contact Carl Schneider at 515-967-5181 or e-mail motorcarl@mchsi.com for more information. This is a Narcoa-insured ride and all Narcoa rules apply.

September 20, 2008 - CO posted 01/10

San Luis Rio Grande & San Luis Central

Alamosa to Center, CO - The Rocky Mountain Division invites you to travel two railroads in the historic San Luis Valley. Set-on at Alamosa, CO on the SLRG, travel to Sugar Junction at Monte Vista where we switch onto the SLC and travel to Center, CO then we return to Alamosa the same day. The distance from Alamosa to Center is approx. 28 miles. Speeder limit will be 25 Cost: \$85.00. NARCOA rules and insurance will be in effect. Jon Keeling will be EC. Contact Philip Walters, PO Box 57, Mancos, CO 81328 (970) 533-7177 or pwalters@frontier.net

September 20 - 21, 2008 - NY posted 04/02

New York Susquehanna & Western Railway, Syracuse Branch

The Volunteer Railroaders Association is pleased to sponsor a 2-day run over the NYS&W Syracuse Branch September 20 and 21, 2008. Participants will travel approximately 160 round-trip miles between Chenango Bridge, NY and Syracuse, NY over the two days. Saturday we will be running roundtrip from Cortland, NY to Syracuse, NY where lunch will be on your own at Syracuse's famed Carousel Mall next to the CSX Chicago mainline which hosts many trains per day. Sunday we will run roundtrip from Cortland, NY to Chenango Bridge, NY, lunch will be deli sandwiches for an additional \$9.00 per person. Operators and riders under 18 are not permitted by the railroad. The trip fee is \$120.00 per car which includes the railroad's per car fee. There is a 40 car limit. This is a NARCOA insured excursion, and all NARCOA rules will apply. This is a non-mentoring run. ECs for the trip are KC Smith and Chris Vitz. For trip details contact the VRA at 80 Royal Avenue, Hawthorne, NJ 07506 Tel: (973) 238-0555 or email to: volunteerra@yahoo.com. You can also sign up and pay for the trip with a major credit card via our website at <http://www.vratrips.org>

September 21, 2008 - CO posted 12/19

San Luis & Rio Grande RR (LaVeta Pass)

Fall Colors On LaVeta. The Rocky Mountain Division invites you to: Set-on at LaVeta, CO and travel over the pass to Blanca, CO a distance of 42 miles through the beautiful Colorado fall colors. Return to LaVeta the same day. NARCOA rules and insurance will be in effect. Speeder limit will be 25 Cost: \$125.00 per speeder. Sweeps, wheel chocks, spark arrestors will be required. Jon Keeling will be EC. Contact Philip Walters, PO Box 57, Mancos, CO 81328 (970) 533-7177 or pwalters@frontier.net

October 04 - 05, 2008 - CO posted 02/09

Leadville, Colorado & Southern RR

The Rocky Mountain Division would like to invite you to the Leadville, Colorado & Southern RR. This excursion starts in Leadville, CO and continues up above tree line at 11,000ft, near Freemont Pass and the worlds largest Molybdenum mine at Climax. Come ride with us on the old Colorado & Southern roadbed and experience the life above 10,000ft. This can be a demanding climate to be in. Please be aware of "Mountain sickness". This can effect folks who are coming from "Down Below". Weather changes can happen very quickly here also. Please be prepared. NARCOA Insurance is required by all motorcars. All NARCOA Insurance is required by all motorcars. All NARCOA rules will apply. Forest Service approved spark arrestors REQUIRED. Cost: \$70 per motorcar. Lodging and food are on your own. Contact: Gus Mocilac gus_mary@comcast.net

October 11, 2008 - PA/NY posted 02/09

Wellsboro & Corning Railroad

Railroad is under new management – Not Confirmed – Ride the 70 miles RT of the Wellsboro & Corning Railroad from Wellsboro, PA to Gang Mills, NY and back. Former New York Central. Proof of NARCOA insurance required, all NARCOA rules will be enforced. Registration fee - \$55.00. Note: All CPE rides are rain or shine. No cancellations due to weather. Hard soled shoes required, no sneakers or sandals. Children must be closely supervised at all times. Send check to: Central PA Excursions, PO Box 145, White Deer, PA 17887. Questions: (570) 538-9050 or email firefighter5@jlink.net

October 18 - 19, 2008 - NJ posted 04/02

New York Susquehanna & Western Railway, Southern Division

The Volunteer Railroaders Association is pleased to sponsor a 2-day run over the NYS&W Southern Division October 18 - 19, 2007. On Saturday the participants will travel approximately 100 round-trip miles between Riverdale, NJ and Warwick, NY. On Sunday we will run approximately 60 round-trip miles between Riverdale, NJ and North Bergen, NJ. Operators and riders under 18 are not permitted by the railroad. Trip fee of \$120.00 per car includes railroad costs. Lunches will be deli sandwiches on both days for an additional \$9.00 per person, per day. ECs for the trip are KC Smith and Chris Vitz. There is a 40 car limit. This is a NARCOA insured excursion, and all NARCOA rules will apply. This is a non-mentoring run. For trip details contact the VRA at 80 Royal Avenue, Hawthorne, NJ 07506 Tel: (973) 238-0555 or email to: volunteerra@yahoo.com. You can also sign up and pay for the trip with a major credit card via our website at <http://www.vratrips.org>

October 18 - 19, 2008 - GA posted 12/15

Georgia Southwestern RR

Saturday: Shellman, GA to Eldorado (Bainbridge), GA - 114 RT Miles - This former Georgia, Florida, and Alabama Railway, was one of the first railroads in south Georgia and originally ran from Bainbridge, Ga. to Cuthbert, Ga. Your daily travel will take you through the Georgia farm cities of Lynn, Eldorado, Boykin, Colquitt, Damascus, Arlington, Talman, Edison, Carnegie, and Cuthbert.

Sunday: Shellman to Dawson to Shellman to Eufaula, AL - 93 RT Miles - We will run from Shellman east to Dawson, turn and continue West back thru Dawson all the way to Eufaula, AL. We will cross the Chattahoochee River at Georgetown, GA on a high bridge built in 1962. This former Central of Georgia trackage was competed in 1860. You will travel thru the towns of Dawson, Cuthbert, Morris, Hatcher, Georgetown, and Eufaula, AL. Requirements: You must be a member of NARCOA, have NARCOA Insurance, and have passed the Rules Test. All cars will be inspected. All NARCOA rules will apply. No refunds after September 18, 2008. All op-

erators and passengers must wear a Safety Vest/Shirt while on railroad property. A mobile VHF radio capable of receiving railroad frequencies is strongly encouraged. Please make your check for \$150.00 payable to: Atlanta Railcar Transportation LLC c/o Bobby Moreman - EC, 3520 Cold Springs Lane, Chamblee, Georgia 30341. Full refunds before September 18, 2008. There is a strict limit of 35 motors and a waiting list will be established. moreman@mindspring.com More info at <http://saalembranch.nfshost.com/motorcar/>

October 24 - 26, 2008 - UT posted 03/27
Heber Valley Railroad

The Rocky Mountain Division invites you to come enjoy the scenic Heber Valley Railroad as we travel through the Heber Valley, past Deer Lake and through Provo Canyon. There is a 35 car limit for this run; cost per car is \$85. There will be four round trip runs from Heber City to Vivian Park and back. Set on will be Friday afternoon at 5:00 pm. There will be a Friday sunset run. Saturday, there will be two runs, the first a sunrise run and the second a noon run. There is a picnic ground available at Vivian Park and gourmet Box lunches are available from the Railroad. The weekend will wrap up with a Sunday sunrise run. Total track miles for the four runs will be approx. 128 miles. Spark Arrestors will be required. NARCOA Insurance is required by all motorcars. All NARCOA rules will be applied. Checks should be made out to "Rocky Mountain Division". Contact: Lynn French email- flf450@aol.com Mail- 38688 Indian Head Lane, Crawford, CO 81415 (970) 921-7700 More details can be found at http://www.rockymountaindivision.com/heber_2008.htm

October 25, 2008 - IA posted 01/15
Iowa River Railroad

Eldora, Iowa - The First Iowa Division will ride this ex-M&StL line which runs from Marshalltown to Steamboat Rock, Iowa and north past the ethanol plant to Ackley. Mileage is about 70 miles round trip. We plan on possibly riding the line twice if time permits. Cost of this ride is \$45 per car. The set on time will be at 7:00am with an 8:00am departure. The set on location is about 2 blocks north of the Hwy 175 crossing. Motels in Eldora are the Village Motel (641-939-3441) and the Eldora Motel (641-939-2232). Both of these motels are small and family-owned so there is a limited number of rooms at each so make your reservations early. Dave Pratt (515-674-3803) is the Excursion Coordinator for this ride. Contact Carl Schneider at 515-967-5181 or e-mail motorcarl@mchsi.com for more information. This is a Narcoa-insured ride and all Narcoa rules apply.

November 1 - 2, 2008 - GA posted 12/15
Chattooga & Chickamauga RR

Saturday: Central of Georgia Line. We will be traveling up a beautiful valley and cross the last ridge of the Blue Ridge Mountains just before Chattanooga. A portion of your trip will be through a part of the Chickamauga National Battlefield. Approximately 90 miles RT.

Sunday: The TAG Line. Our motorcar excursions begins in the suburbs of Kensington and we will travel to Chattanooga and return. This will be on the last remaining section of the Tennessee Alabama & Georgia Railroad (The TAG Line), which ran between Birmingham and Chattanooga. Approximately 42 miles RT.

Requirements: You must be a member of NARCOA, have NARCOA Insurance, and have passed the Rules Test. All cars will be inspected. All NARCOA rules will apply. NARCOA approved Hi-Rail Vehicles OK. No refunds after October 1, 2008. All operators and passengers must wear a Safety Vest or Safety Shirt while on railroad property. A mobile VHF radio is strongly encouraged. The cost for both days is \$150.00. This year I am not able to divide up the days as in the past. There is a limit of 35 motorcars for this fall color adventure on rails. Please make your check payable to: Atlanta Railcar Transportation LLC c/o Bobby Moreman - EC, 3520 Cold Springs Lane, Chamblee, Georgia 30341. Click here for a brochure. No refunds after October 1, 2008. moreman@mindspring.com More info at <http://saalembranch.nfshost.com/motorcar/>

November 16, 2008 - NC posted 03/19
Great Smoky Mountains RR

This is our annual FALL OPEN HOUSE RUN where Tom Falicon hosts an open house with great food and plenty to see at his Bryson City shop/RR the day before the run, (November 15th). Set-on will be at the Nantahala

Outdoor Center, North Carolina with a run westbound to Andrews where we'll turn and run eastbound all the way to Bryson City. Total round trip miles will be 68 miles. Cost is: \$85.00. For a sign-up form or more info, contact: E.C. Tom Falicon, 1227 Sawmill creek Rd., Bryson City, NC 28713, Ph: 828-488-8063 or email; Raildawg@gte.net

December 06, 2008 - PA posted 02/09
North Shore Railroad

CPE is pleased to sponsor a 1 day run on the North Shore Railroad - ANNUAL TOYS FOR TOTS RIDE - Ride the 86 miles RT of the North Shore Railroad from Northumberland to Berwick and return. This is former Erie Lackawanna track. As part of the fee for this ride, please bring a new, unwrapped toy with you for either a boy or a girl. The Toys for Tots folks will be on hand to collect the toys. We hope to have good press coverage for this event. The public will be invited to bring a toy also and to see your motorcars. There will also be prizes for the best Christmas theme decorated motorcars. Proof of NARCOA insurance required, all NARCOA rules will be enforced. Registration fee - \$55.00. Note: All CPE rides are rain or shine. No cancellations due to weather. Hard soled shoes required, no sneakers or sandals. Children must be closely supervised at all times. Send check to: Central PA Excursions, PO Box 145, White Deer, PA 17887. Questions: (570) 538-9050 or email firefighter5@jlink.net

Each year the May / June issue of The SETOFF has the largest number of excursion announcements. Due to space limitations, the For Sale and Wanted items could not be included. - Editor

NARCOA COMPANY STORE



The clear plastic wheel profile is necessary to determine if the wheel is flat, thin in the flange area, or has wear between the flange and the flat section of the tread. Use the wheel profile as your first step in diagnosing "hunting" on the rails. Use two of the clear plastic wheel profiles to determine track gauge. The metal caliper gauge is necessary to determine if you have the required 1/8" minimum wheel thickness in the flange area. Plastic wheel profiles are \$6 each plus \$4.25 shipping. Metal wheel calipers are \$10 plus \$5.65 shipping. One profile and one caliper with shipping included is \$20. Make checks payable to NARCOA. Send to Hank Brown, 622 Oak Street, Cottage Grove, WI 53527. Questions? Call Hank at (608) 839-4939 or email wildernesstours@charter.net

See the website for Reproduction Fairmont Data Plates that fit on your engine cover, and NARCOA Trainman Battery Lanterns. www.narcoa.org/accessories/accessories.htm



**PATRICK W. SMITH
INDIVIDUAL AFFILIATE**

Hi, I am Smitty, an Individual Affiliate Excursion Coordinator from Baker City, Oregon. All I run anymore is 36" narrow gauge excursions. I am a retired Locomotive Engineer from a Class 1 railroad here in the Pacific Northwest. I have been railroading, and around railroads,



Narrow Gauge Gang founders "Smitty" and Dudley Newman with Smitty's M-19 "Slim Princess."

now for 40 years. I am the excursion coordinator for the Sumpter Valley Railway (SVRy), in Oregon, for the Durango & Silverton Narrow Gauge Railroad



Motorcars on the famous "High Line" rock cut at mile post 469 above the Animus River on the D&SNGRR.



The westbound C&TS train from Antonito approaches the group waiting on the siding at Osier, mile post 318.

(D&SNGRR), in Colorado, and for the Cumbres & Toltec Scenic Railroad (C&TS), in Colorado and New Mexico. I have been the EC for the C&TS for approximately 12 years, for the D&SNGRR for 10 years and for the SVRy 7 years. I was also the first EC to arrange a couple runs on the Grand Canyon

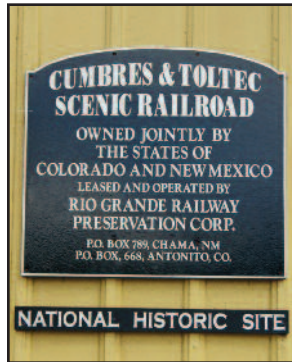

Railway out of Williams, Arizona when I lived in Arizona.

I no longer have any standard gauge equipment, but I do have a few pieces of narrow gauge: an M-19 called "The SLIM PRINCESS," 2 - A-6's, a 1930 Model "A" FORD Depot Hack named "BUSTER," a hand-pump car, a Velocipe, a Nordberg track spiker, and a 1927 20 ton Plymouth, model HL-4, LP gas mechanical locomotive. I have sold 4 narrow gauge Fairmont motorcars

that I once owned and restored.

The Colorado and New Mexico Railroads are by far the most scenic and breathtaking in the United States. It was very difficult to get an excursion on the D&SNG. Every time I drove there (470 miles one way) to talk with them for 3 years they would listen to my spiel and pretty much laugh at me! My persistence finally paid off and the group has had a very enjoyable time there every year. On



"Buster" Photo by Smitty. Other Photos by Editor.

both the C&TS and D&SNG I have had multiple contact persons with changes in personnel, but the good safety record keeps the doors open. I am proud to mention that the Narrow Gauge Gang's safety record is impeccable and that goes a long way with the narrow gauge railroads I am the EC on, as that safety record is always brought up each year by the railroads when I re-negotiate for the year's runs.

I keep an e-mail list of individuals that have, or are interested in, narrow gauge motorcars. My friend Dudley Newman, in Arizona, and myself started the NARROW GAUGE GANG. If you would like your name added to the list, contact me at smitty@budgetusa.net. See you on the rails!

Smitty